

## VCF 2612 (1.2) - Build Document

This is a clone of the 4012 VCF used in the ARP 2600.

Other than some substituted parts and a layout mainly adjusted for the eurorack standard, I have tried to keep all the original quirks as close to the original as possible.

That said, due to the offset in the 2600 VCO Saw & Pulse, 2x 470nF capacitors have been added to the Audio inputs to make them AC-coupled. (if you're going original, feel free to put a wire here instead)

2x 2N5459 have been used instead of the Dual JFET 2N3958, as the latter is pretty rare and expensive. There are markings on the board to assist if you decide to use 2N3958.

As it have a slightly different pinout, a few legs will need to be bent.

I would highly suggest matching the 2N5459's if going that way, else the filter might not work properly, and the trimming process could be hard/impossible to get right.

Luckily matching is a simple task with just a piece of breadboard and a DMM.

ARP used a 250R Trimmer for the 1V/OCT Scaling, which again is rare and somewhat expensive, if you actually do find one.

I use a 500R Trimmer instead, which works just fine. 250R is printed on the board however.

It wouldn't be wrong to match the BJT's, but I personally don't hear/see any difference from using BJT's from the same tape. They are usually pretty matched anyway.

There are markings surrounding the ladder transistors, but if there should be any confusion about that Q8-Q15 are all 2N3904's.

The 1K87 tempco is a good idea if you intend to use this VCF as an Oscillator in self resonating mode. It will still track well with a standard resistor there instead, but it will drift a bit.

There are Buffers added on the Control-PCB. Feel free to bypass them if originality is important to you.

Thats about it, get to it!

- Rickard Steffensen / [steffcorp.se](http://steffcorp.se)

# BOM

Resistors		Capacitors		Semiconductors		Pots & Jacks		Etc.	
Part	Pcs	Part	Pcs	Part	Pcs	Part	Pcs	Part	Pcs
220R	1	10pF	2	2N3904	14	100K Aud 9MM	2	8-pin Single Row Male Header	2
470R	6	22pF	2	2N3906	5	100K Lin 9MM	5		
820R	1	47pF	4	2N5459	2	Jacks	6		
1K	2	10nF	4	LM301	1		8-pin Single Row Female Header	2	
1K8	1	100nF**	6	TL072	1				
2K2	1	470nF	2	TL074	1				
3K32	4	10uF	2	1N4148	4		10-pin Power Header	1	
10K	1			1N5817	2				
15K	3								
23K2	1								
30K1	4								
56K	1								
100K	20								
110K	1								
150K	2								
196K	1								
220K	1								
3M3	1								
1K87 (TC)	1								
250R* (TRIM)	1								
10K (TRIM)	1								
100K (TRIM)	2								

\*500R works fine

\*\*monolithic ceramic

## TRIMMING

Its important to leave the VCF powered up for at least 15 min before trimming.  
Also don't panic if the VCF seems to not do anything when first powering it up,  
it comes alive through the trimming process.

<b>R164 FREQ Cal</b>	<ol style="list-style-type: none"><li>1. Monitor VCF output with an oscilloscope or a frequency counter.</li><li>2. FREQ fully off.</li><li>3. FINE in middle position.</li><li>4. RES at max.</li><li>5. All input controls fully off.</li><li>6. Adjust R164 FREQ Trimmer for 10Hz output.</li></ol>
<b>R153 1V/OCT</b>	<ol style="list-style-type: none"><li>1. Connect a Keyboard to KBD CV input and depress low C (0 volts)</li><li>2. Adjust FREQ and FINE for 200Hz.</li><li>3. Depress C three octaves higher and adjust R153 1V/OCT Trimmer for 1600Hz.</li><li>4. Repeat steps 2-3 until low C remains at 200Hz and C3 remains at 1600Hz.</li></ol>
<b>R162 OFFSET</b>	<ol style="list-style-type: none"><li>1. All controls fully off.</li><li>2. Adjust R162 OFFSET Trimmer for minimum d.c. output.</li></ol>
<b>R163 GAIN</b>	<ol style="list-style-type: none"><li>1. FREQ at max.</li><li>2. RES fully off.</li><li>3. Connect your waveform to any of the Audio inputs.</li><li>4. Fully open the Volume attenuator for the waveform input.</li><li>5. Adjust R163 GAIN Trimmer for same amplitude as the inserted waveform.</li></ol>

Above is the original Trimming procedure, what I like to do is below:

<ol style="list-style-type: none"><li>1. Monitor VCF output with an oscilloscope or a frequency counter.</li><li>2. All controls fully off.</li><li>3. Adjust R162 OFFSET Trimmer for minimum d.c. output.</li><li>4. FREQ fully off.</li><li>5. FINE in middle position.</li><li>6. RES at max.</li><li>7. Adjust R163 GAIN Trimmer for an LPF output of about 7.5V.</li><li>8. Adjust R164 FREQ Trimmer for 10Hz output.</li><li>9. Steps might need repeating until perfected.</li></ol>
<ol style="list-style-type: none"><li>1. Connect a Keyboard to KBD CV input and depress low C (0 volts)</li><li>2. Adjust FREQ and FINE for 200Hz.</li><li>3. Depress C three octaves higher and adjust R153 1V/OCT Trimmer for 1600Hz.</li><li>4. Repeat steps 2-3 until low C remains at 200Hz and C3 remains at 1600Hz.</li></ol>

# LAYOUTS

Core-PCB:

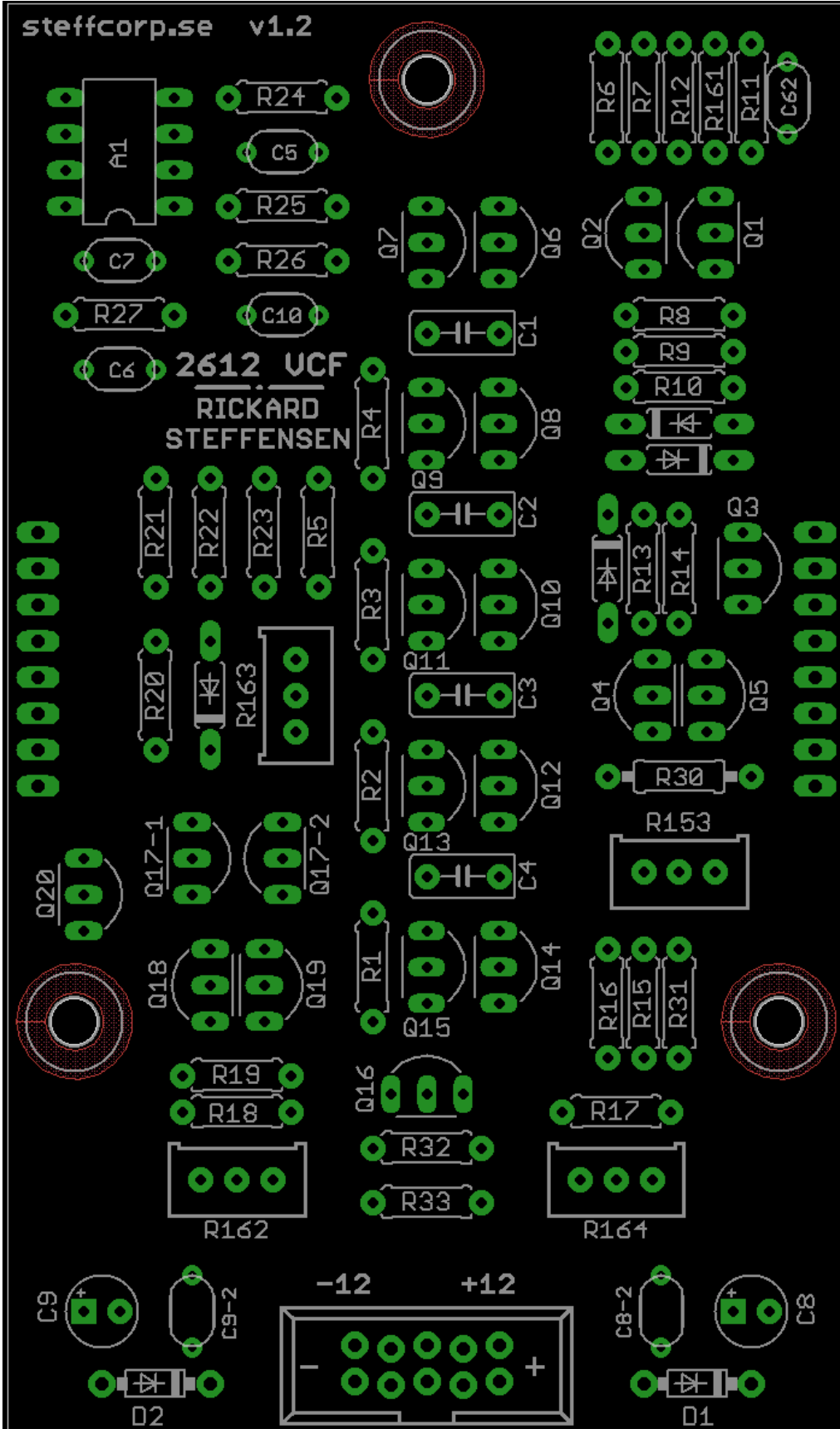

Control-PCB:

