

2P6P

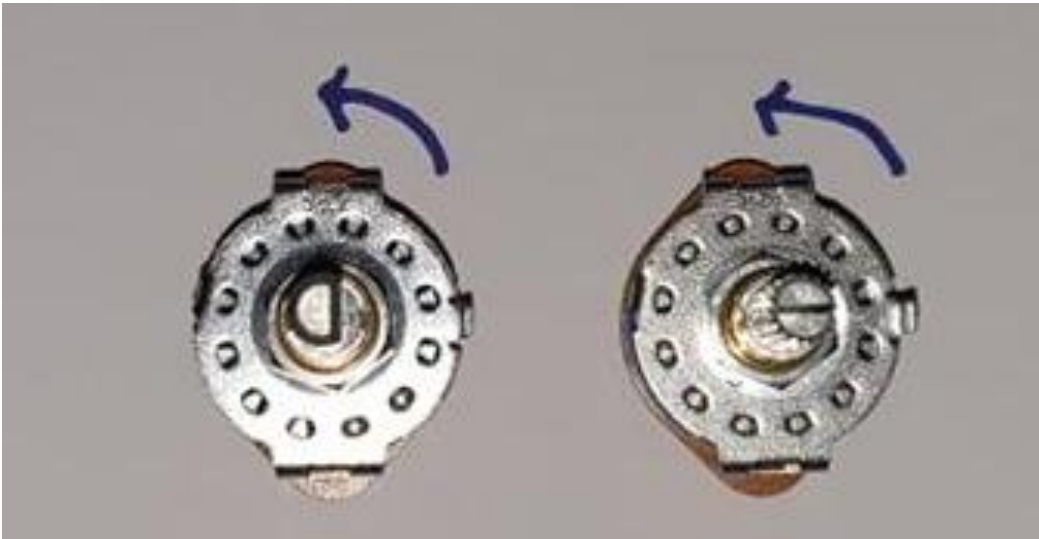

Place both parts in the same position, tab facing to the right.



Rotate both shafts fully anti-clockwise



With a pen make a mark on the tab, the inner gear, the plastic disc and the base pcb wafer.



Rotate both fully clockwise



Using pliers, bend the 2 little metal pins on each side, so that they are straight and can pass through the hole in the base.

Do not squeeze too hard on the pins, be sure not to close them together. You should only move them enough so that they can pass through the hole. If you do not do this correctly, it will make it harder to assemble the rotary later.



Separate both sections

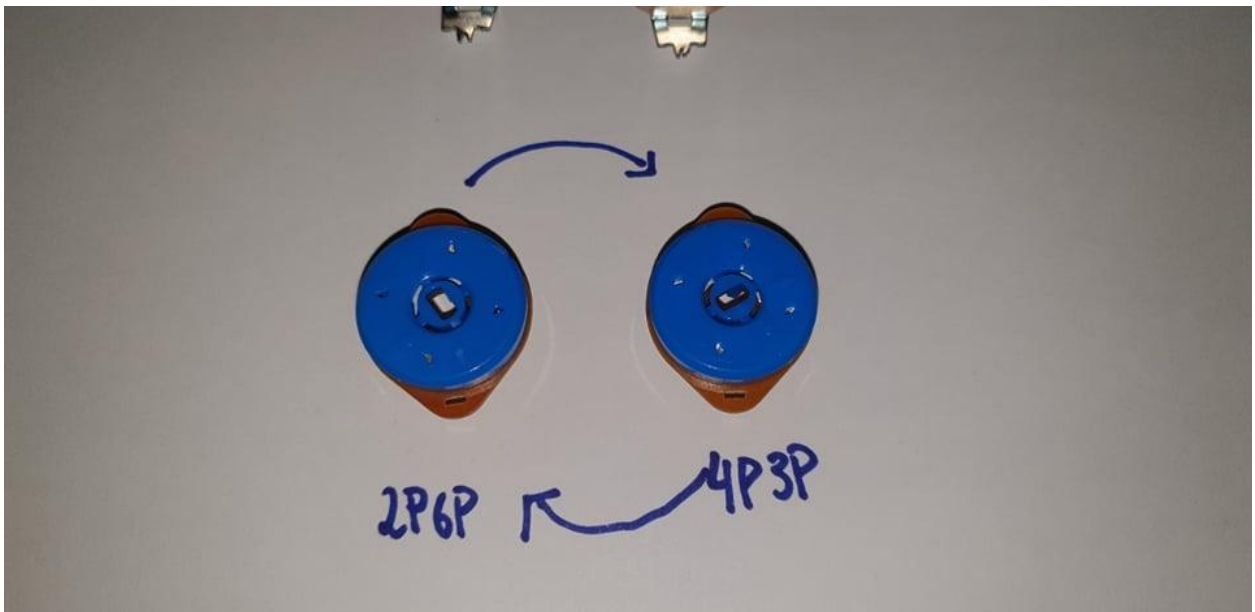

Switch the entire base

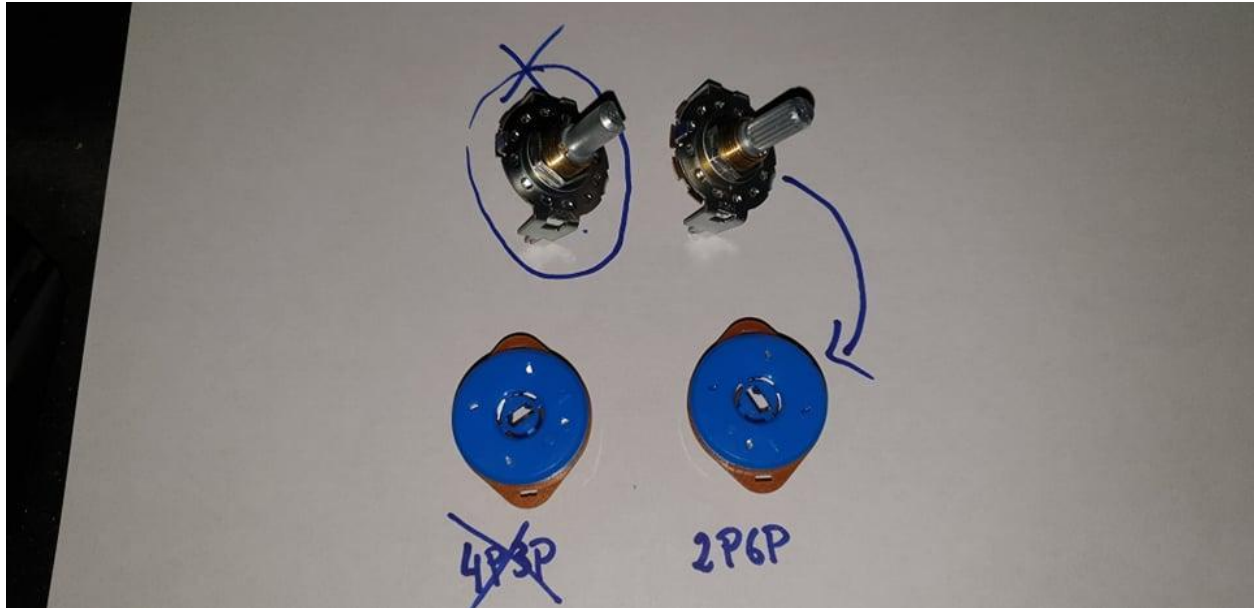

The parts on the left are not needed, the top section with a T18 (knurled) will go into the 2P6P base section to create the part we need.

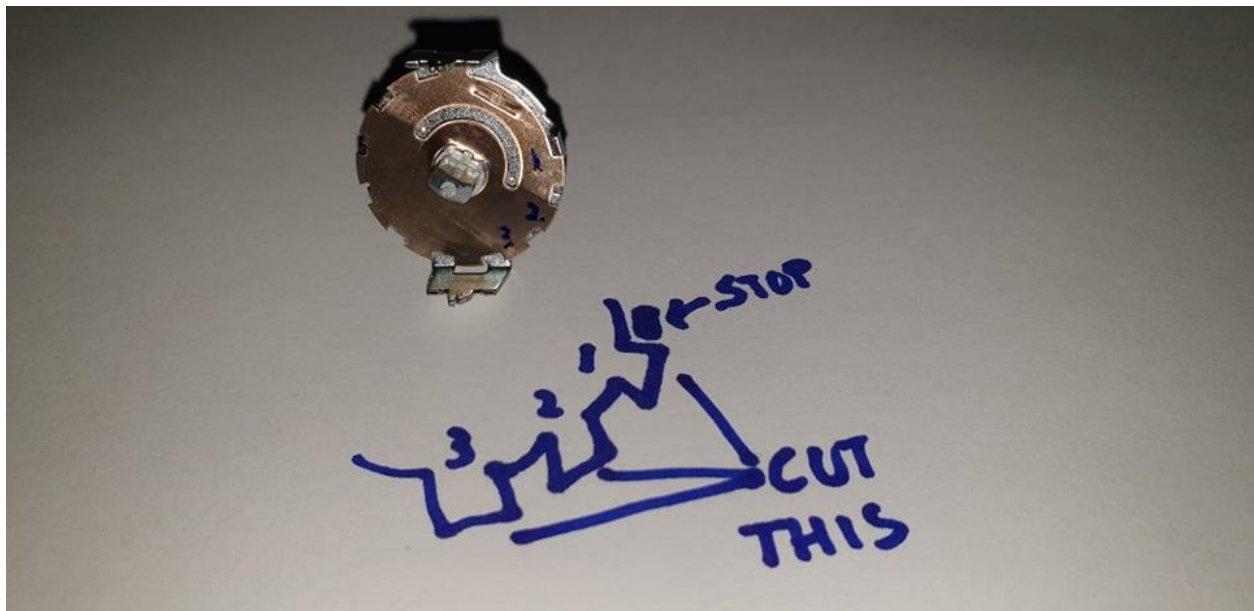

Use a pen to mark the gears 1,2 and 3 as shown in the picture. The switch will not rotate clockwise as far as we need, so we need to carefully cut and remove these three gears. See next picture before proceeding.



The final result should look like this, take your time and double check before you cut.

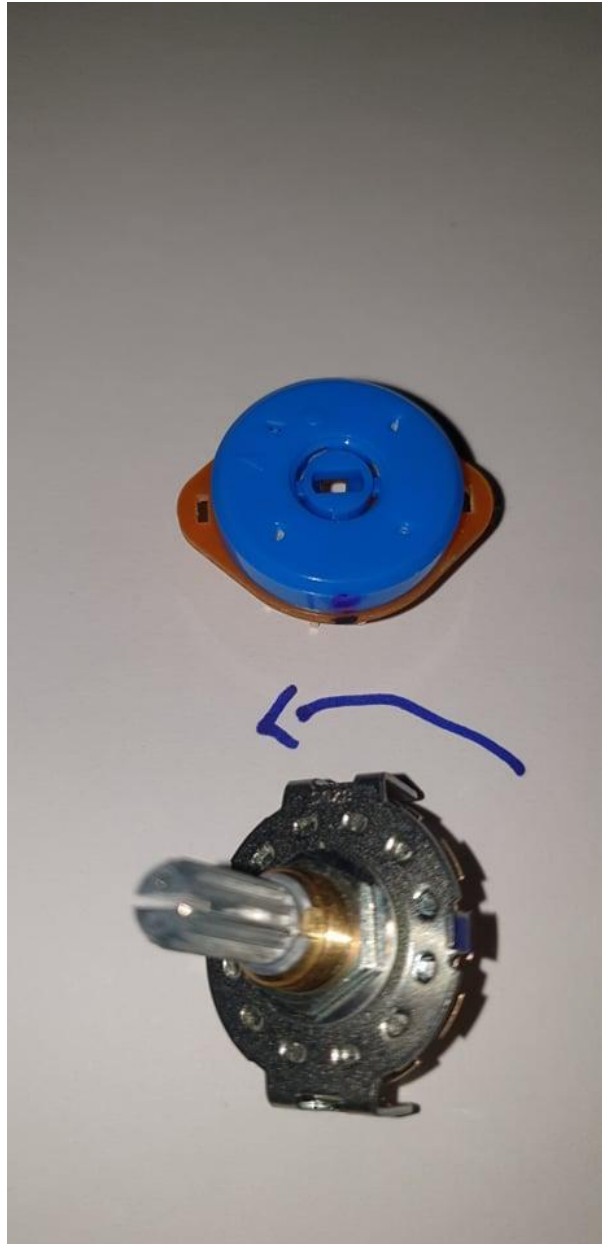

Next rotate the shaft fully anti-clockwise. You should now be back at position 1. Check that the base and the plastic part are aligned with the mark you made in step 3 and align this mark to the tab you also marked earlier. Assemble it and bend the pins out to lock everything in place.

1P12P Endless

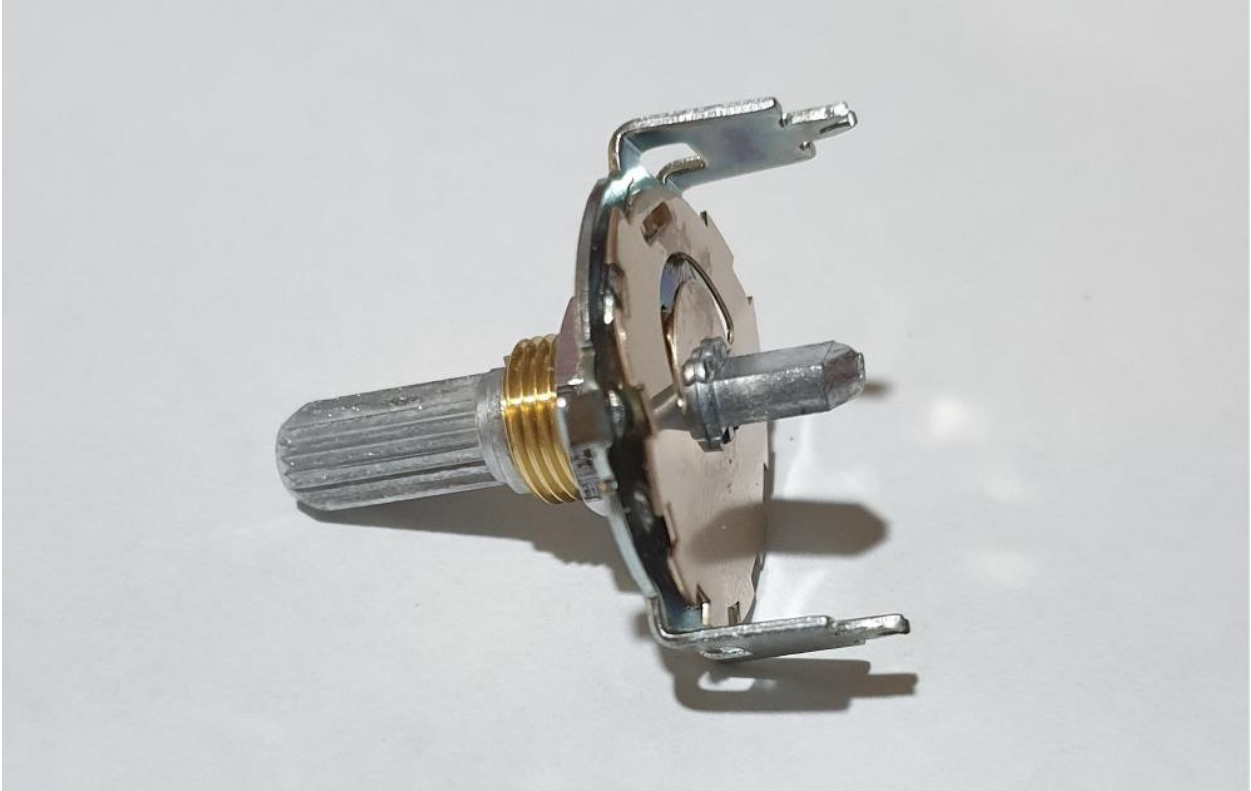

*Follow the exact same steps to open and switch the base of the 1P12P endless rotary.
There is no need to mark it or keep track of the position.*

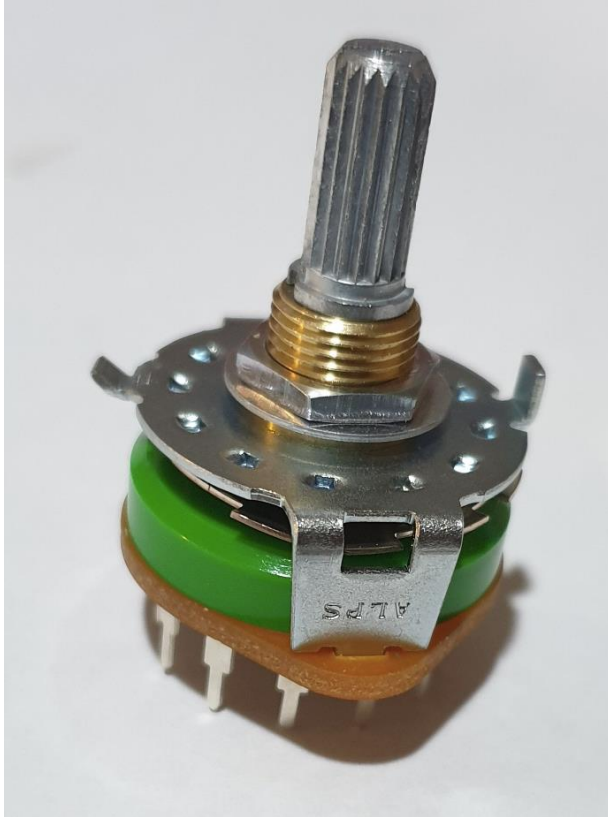

No need to file any gears this time. We just bend the stopper tab up (shown on the left in the picture) so that it does not block the switch from rotating.

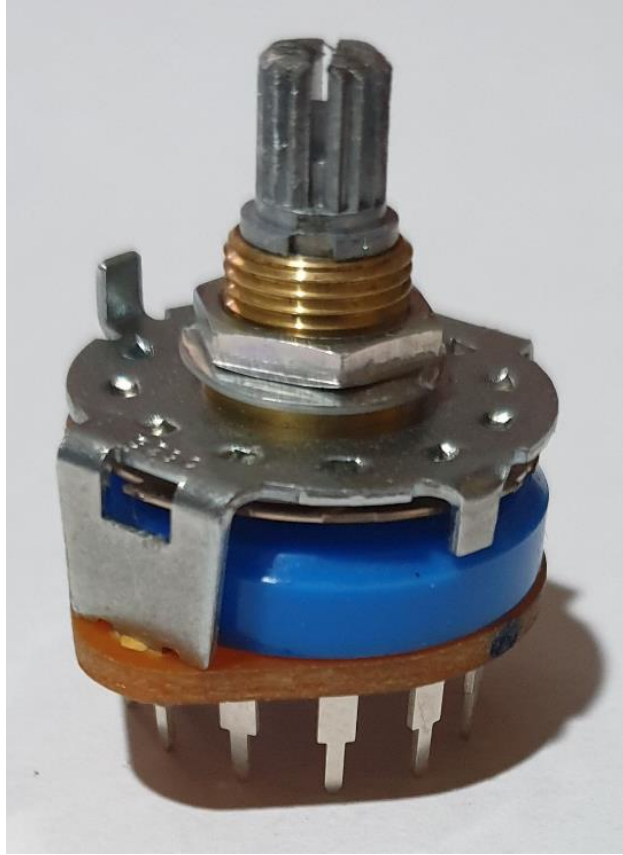

Cut 5mm from the top of the shaft of all three completed modded parts.

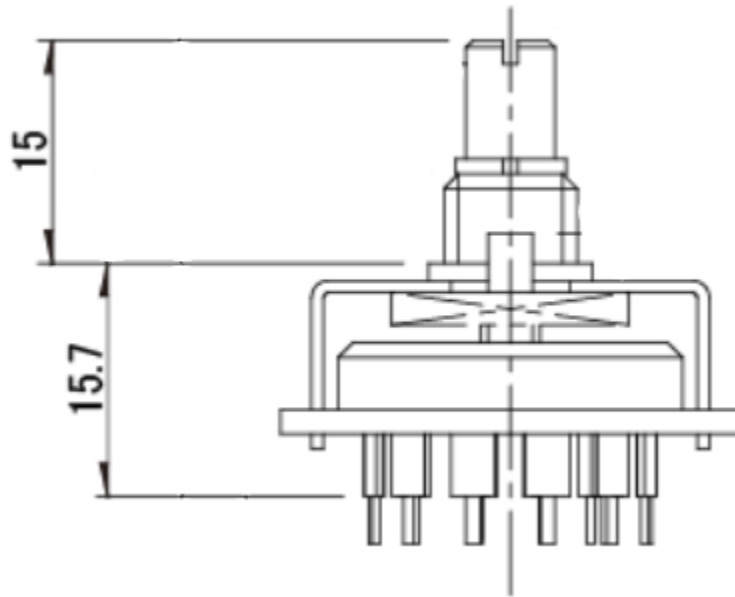

End result measurements

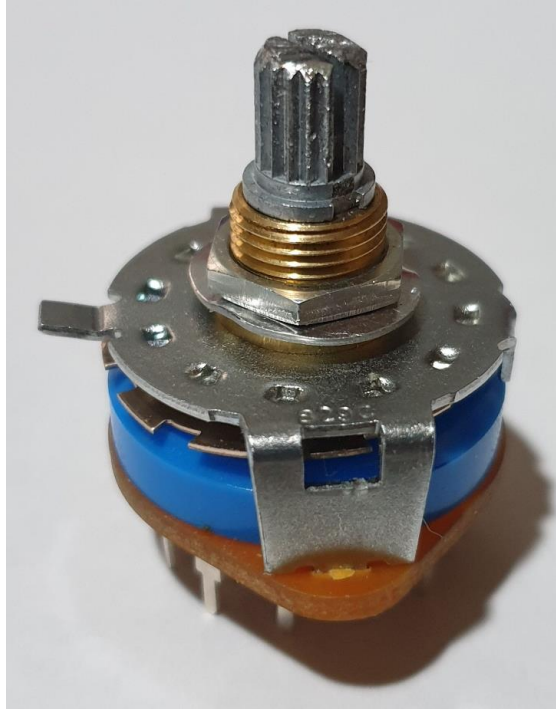

Bend the tab marked in step 3 into an horizontal position, now ready for installation.