

Jasper Synthesizer construction guide

Contents

Introduction – About Jasper.....	3
Features.....	4
Extra features.....	4
Changes to the electronics/layout.....	5
Power Consumption.....	5
Component notes.....	6
Building Jasper.....	6
Tools required.....	7
Panel / Enclosure.....	7
Starting Construction.....	8
Soldering.....	8
Link wire.....	8
Resistors, diodes, ferrite bead.....	9
IC sockets.....	10
Ceramic capacitors.....	11
Box Capacitors, transistors, power regulator.....	12
Trimmer potentiometers.....	13
MTA100 PCB Headers.....	13
Electrolytic capacitors.....	14
Jack and DIN Sockets.....	14
Link port cable.....	15
Panel Spacers.....	16
Switched Potentiometers.....	17
Rotary Switches.....	19
Preparing the 16mm Potentiometers.....	21
Keyboard sense and Tune pots.....	24
Soldering the Potentiometers.....	24
Panel Mounted Controls – 9mm Mix Potentiometers and Hold Switch.....	26
First power up test.....	30
Install the ICs.....	30
Battery holders.....	31
Speaker.....	32
Enhanced Mode PCB.....	32

Testing and setup.....	33
Initial control setup.....	34
Power.....	34
Keyboard sensitivity setup.....	35
VCA Envelope trimmer.....	35
LFO Trimmer.....	36
VCO Separation Trimmer.....	36
Tuning to A440.....	37
Further checking and troubleshooting.....	37
Options.....	38
Link Wiring.....	38
Full size 7pin DIN connection.....	38
Internal MIDI-Link converter.....	38
Quarter inch jack sockets.....	39
Power Options.....	39
Further Information.....	40
More about the Wasp.....	40

Introduction – About Jasper

Jasper is a clone of the Wasp synthesizer that was made by the small British company *EDP* (*Electronic Dream Plant*) for a few years from 1978 to 1982.

The Wasp was one of the first commercially available digital/analogue hybrid synthesizers. Designed by Chris Huggett and Adrian Wagner who created it as an affordable synthesizer using the then newly and widely available inexpensive CMOS digital logic chips.

Jasper retains the features and controls of the Wasp, including the touch keyboard, and the Link port to allow digital connection between similar equipment. It also adds a few extra features while retaining the essential nature of the original.

It is designed to be straightforward to construct, and flexible in arrangement. It can be built to the same specifications of the original Wasp – or tricked out with a few modifications and options. The enclosure can be as simple as a couple of CNC or laser-cut plates to protect and support the PCB and controls – or something more elaborate and durable like the Wasp Special. There's no reason why it couldn't be turned into a completely rack-mount unit, as some original Wasps were modified.

This guide shows one way to build up the Jasper PCB. There are several options, so think about how you are going to use the synth, and what extra features you wish to incorporate. It is also a good idea to think a little about how you are going to mount or enclose your finished PCB.



Features

Jasper shares all the main features with the original Wasp:

- Two digitally controlled oscillators (DCOs) with pulse and ramp waveforms.
- Digital pseudo-random white noise source
- Low frequency oscillator (LFO) for control (about 0.55Hz to 100Hz)
- Voltage controlled filter (VCF)
- Voltage controlled amplifier (VCA)
- Two envelope generators for controlling the filter and VCA
- Two octave capacitive touch 'keyboard'
- Headphone and line out ports
- Built-in speaker amplifier to power an 8ohm internal speaker
- 'Link' port to connect to other Jaspers (Wasps, Gnats or Spiders)
- Battery power optional

Extra features

Jasper has a few extra features not on the original Wasp synthesizer:

- Mix level control for each oscillator – similar to Wasp Deluxe
- Audio input, with variable gain. This can be mixed with the oscillators or noise source (the Wasp Deluxe had external input, but this apparently was wired directly to the oscillator switches meaning you had to switch out an oscillator if you wanted to process external audio)
- Notch filter mode, in addition to low, high and band pass filtering. The low-pass and high-pass filter signals are mixed cutting out the signal at the filter frequency.
- Low dropout voltage regulator for longer operating time on batteries.
- Designed to run on 8 NiMH AA batteries (nominal 9.6V) with PCB mounted battery holders. Other power options are possible.
- Power LED to show when the synth is switched on.
- Power over the Link port. Using an 8-way mini-DIN cable it's possible for one Jasper to power another. One set of batteries can be used for several Jaspers, a sequencer, or Gnat clone. This is not possible with the original 7way Link cables.
- A small add-on PCB is provided to implement an 'enhanced' oscillator waveform like that on the Gnat synthesizer. This is a pulse width modulated square wave, controlled by with a simple fixed 0.3Hz LFO. This is attached with a flying lead to the main PCB via a 4 pin header. This 'enhanced' wave is available on the oscillator waveform switch – and each oscillator has its own header, expanding the available palette of sound.
- Envelope hold switch. This prevents the envelope from decaying, allowing the synth to make sound without keeping your finger on the keyboard. Useful for making drones or setting up sounds.

Changes to the electronics/layout

Compared to the Wasp, there are a number of minor changes to the electronics and controls:

- All potentiometers and switches are mounted to the top side of the PCB. They are bolted to the panel. On the original Wasp they were bolted to the PCB.
- Minor adjustments to some component values have been made to account for lack of current availability of 2 Megohm potentiometers – 1M potentiometers are used instead.
- Audio jacks are 3.5mm soldered directly on the PCB – these allow easy connection to modern devices. If 1/4" jacks are required, these can be connected with flying wires. Both the line and headphone sockets are wired to allow connection of stereo cables to easier connection to modern equipment. The audio output is mono – it just outputs on both channels.
- Link port connectors are replaced with PCB mounted 8 way mini-DIN sockets. This prevents getting the Link port confused with MIDI. A mini-DIN to DIN cable could be made if you wish to connect to original EDP gear, or 7pin DIN sockets can be connected with flying wires.
- There are three switched potentiometer controls. These are pretty rare these days in the values needed – the only manufacturer that seems to have a few stockists is Omeg, so the PCB is designed for their PC16ECO series pots with switches. These also dictate the height of the control panel above the PCB.
- CA3080 OTA chips have been replaced with easier to find LM13700 dual OTAs.
- The transistors replaced with commonly available BC547, BC557s (2N3904/2N3906 will also work if placed backwards to the silk-screen marking).
- A low drop out voltage regulator is used to allow for longer running times on battery power.

Power Consumption

With CMOS 555 chips and all TI CD4000 series ICs and MCP1702-5002 voltage regulator, measured power consumption was:

- approx 30mA – 40mA not using built-in speaker
- approx 150mA – 200mA while outputting audio through internal speaker

Component notes

With the exception of the CD4006 all the components are pretty standard, available from good electronic component suppliers. Resistors are all 1% metal film. Ceramic small value capacitors are all C0G type. Medium value capacitors (up to 1uF) are all polyester film. Larger capacitors (2.2uF and up) are electrolytics. On the Wasp some of these capacitors would have been tantalum – however modern low ESR electrolytic capacitors seem to work fine in Jasper. Apart from the 4006 mentioned above, all the ICs are currently in production and available. In the prototypes, all new CD4000 series chips from Texas Instruments have been used – but other brands should be fine.

Check the BOM for suggested suppliers.

Obsolete chip alert: The only CMOS chip used in the synth that is not currently manufactured is the CD4006 – this 18 stage shift register is part of the noise generator. This can be sourced from eBay or some dealers may stock it.

Recently TI have discontinued the LM386N amplifier. However this can be replaced by the NJM386B and is available in quantities from Mouser and other suppliers.

Building Jasper

Building the Jasper should be pretty straightforward, however there are a lot of components on a large circuit board. So it's really an intermediate to advanced project.

The guide that follows describes building Jasper with a basic configuration using on-board mini-DIN Link ports, 3.5mm jack sockets and on-board battery holders, and using the Jasper panel PCB. It will create a fully functional unit that can then be built into a suitable enclosure.

You must be proficient in soldering. Care must be taken to ensure everything is soldered correctly – especially every pin of each IC socket.

Debugging skills will almost certainly be required before it works correctly. It's easy to miss a solder joint (or to mis-solder it) and can have strange symptoms. The Jasper circuits have been built and tested with the suggested components and work well, within the limitations of the original design.

Double-check the values of resistors and capacitors before you put them into the PCB. The silk-screen markings on the PCB are quite small so a magnifier may be advisable. Also double-check the values with the BOM – there may have been amendments to some of the values of the components since the PCB was manufactured.

Anti-static precautions should be taken before handling the ICs and inserting them into their sockets. Use a grounding wrist strap, or at the very least ground yourself before handling the chips.

Tools required

Just the basic things needed to construct any electronics kit:

- A good temperature-controlled soldering iron is recommended
- side cutters
- small needle-nose pliers
- wire strippers
- solder sucker or wick for fixing mistakes
- An IC pin straightening tool will be helpful when inserting all the ICs
- An MTA-100 insertion tool (and a small bench vice) is useful for preparing the connectors if you are not soldering wires directly to the PCB.



Some test equipment is advisable for testing the synth's correct operation when you've soldered it all up. A multimeter is essential for checking voltages and component values, and an oscilloscope is recommended for testing the various parts of the circuit.

Panel / Enclosure

It is a very good idea to have a panel available so the controls can be aligned correctly when they're soldered onto the board. This can be the PCB Panel as available with the Jasper PCBs, or laser-cut, cut with a CNC router, or simply drilled by hand or with a drill press.

Before you start, it's also a good idea to plan for the type of case or enclosure you intend to put the Jasper PCB in. Will you be using the on-board connectors or connecting jacks by flying wires to their pads? Are you using the on-board battery holders, or providing for a different internal power supply? Are you including extra circuitry like MIDI or CV/Gate adapters?

It is possible to test and use Jasper on the workbench without an enclosure.

Starting Construction

Before starting, check the PCB. Make sure it is not damaged.

It is a good idea to make some basic electrical checks.

Verify that there are no shorts between 5V and ground using the continuity tester of your multimeter. Likewise check for continuity on the 5V rail – make sure that the 5V pin of each IC connects to the 5V VO pin at IC13 the voltage regulator. The 5V pin on most of the ICs is top left of each IC – pin 14 or pin 16 depending on the chip(not the 555, LM13700). Also in a similar way check the ground rail. On most of the ICs this will be the pin 7 or 8 on 14pin or 16pin chips.

Soldering

Link wire

First solder the 35mm long link wire in the centre of the board to the left of IC31. Use solid core insulated hook-up wire.

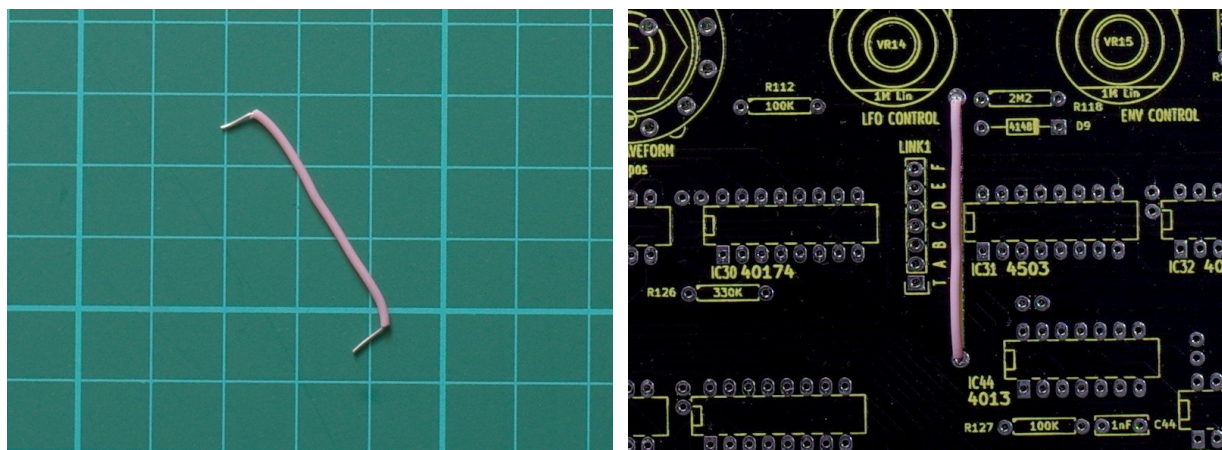

If you are using the on-board battery holders, solder link wires at the top of the board to connect the battery holders to the internal power header.

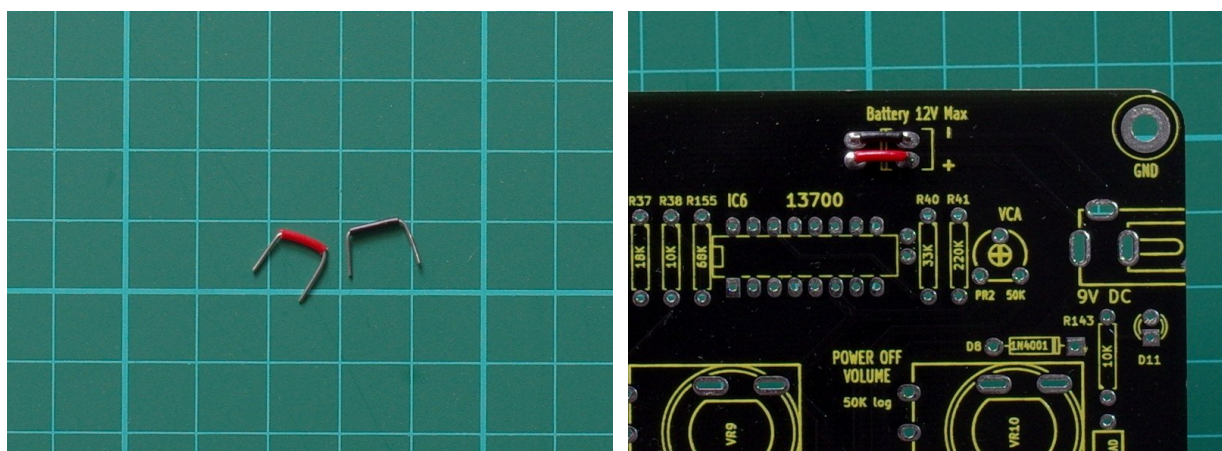

If you are *not* using the PCB battery holders, you can solder a two pin MTA100 header onto the pads with the silkscreen markings. When you make up a power lead that connects here, double check that you get the polarity correct. Red wire should go to the +ve pin, black to the -ve pin.

Resistors, diodes, ferrite bead

Next the smallest 'low-lying' components first – resistors and diodes. Ensure the diodes are the correct polarity – the line on the diode must match the line on the silkscreen. Do not solder the power LED yet. If you don't have one available, the ferrite bead can be replaced with a link wire or 10ohm resistor.

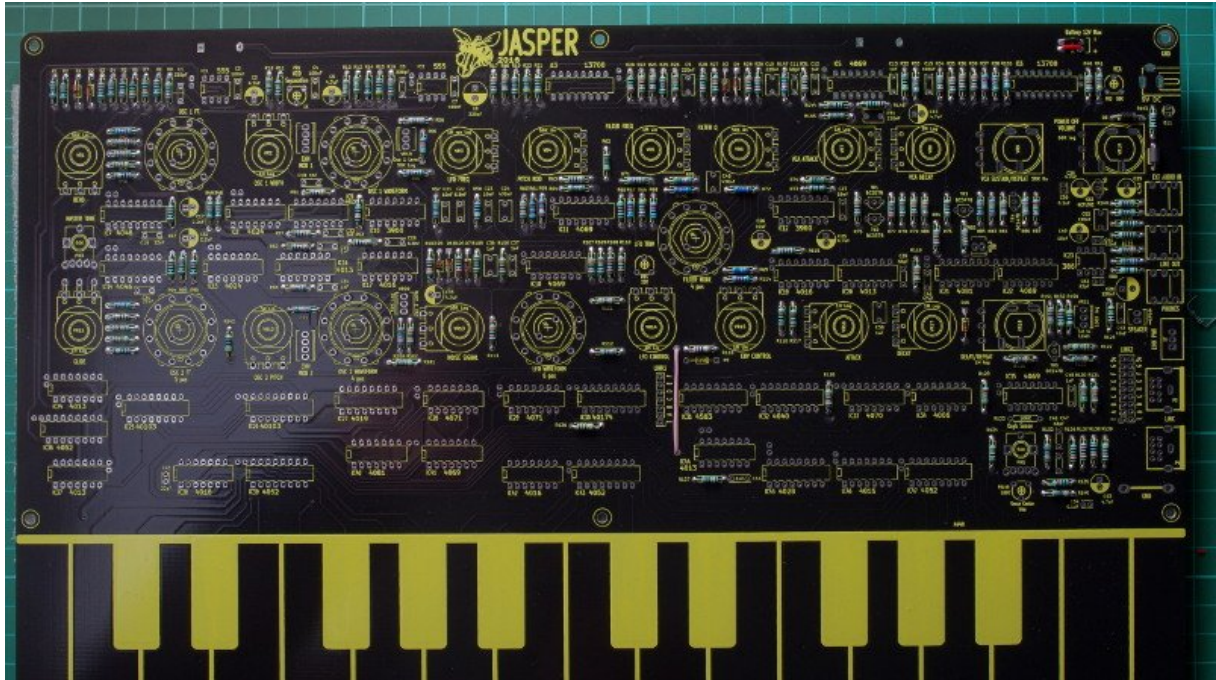

Resistors and Diodes

IC sockets

Solder the 45 IC sockets. Make sure they are oriented correctly. With the keyboard facing you the notch on each of the sockets point to the left side of the PCB.

Make sure the sockets are flat on the PCB – it's a good idea to just solder a single pin of each socket, then turn the board over and inspect the socket. If it is not flat to the board, re-melt the solder on the one pin while pushing the socket down. Once the socket is flat, solder the remaining pins, and re-flow the solder on the first pin.

It is probably a good idea to solder the sockets in several stages, taking a break to check as you go along.

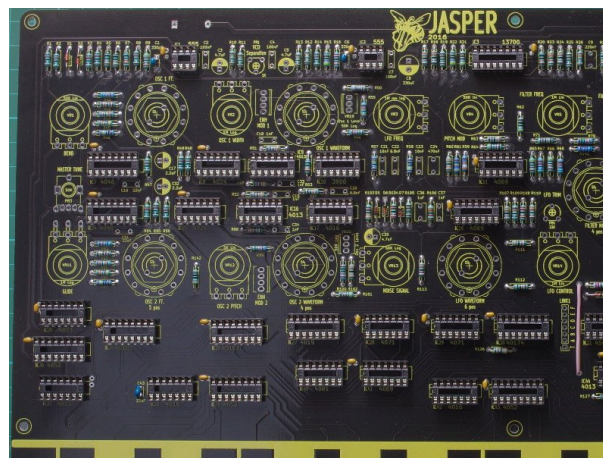
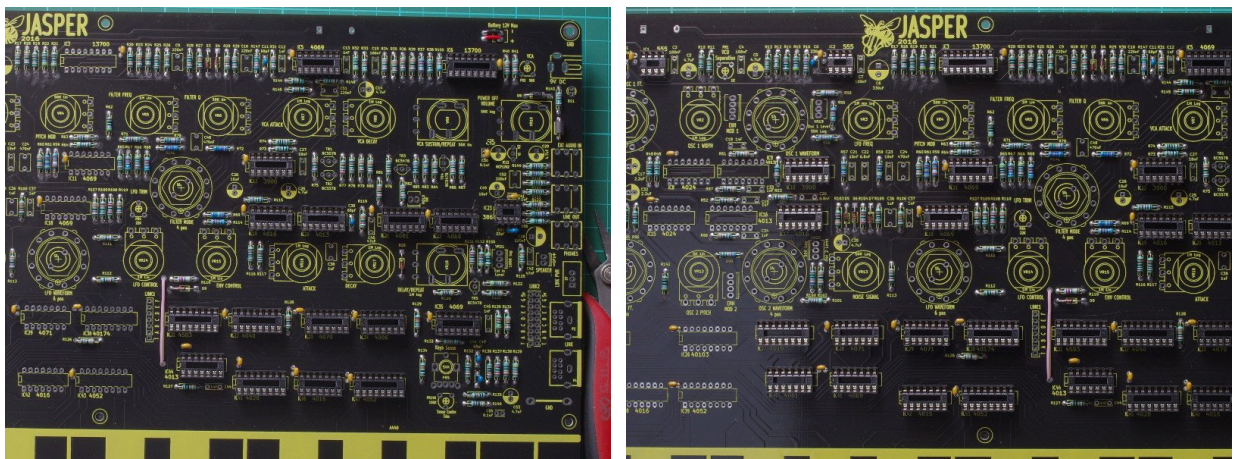

Afterwards double check that all the socket pins have been soldered. There are a lot of them and it is easy to miss one or two.

Ceramic capacitors

Small ceramic capacitors are next.

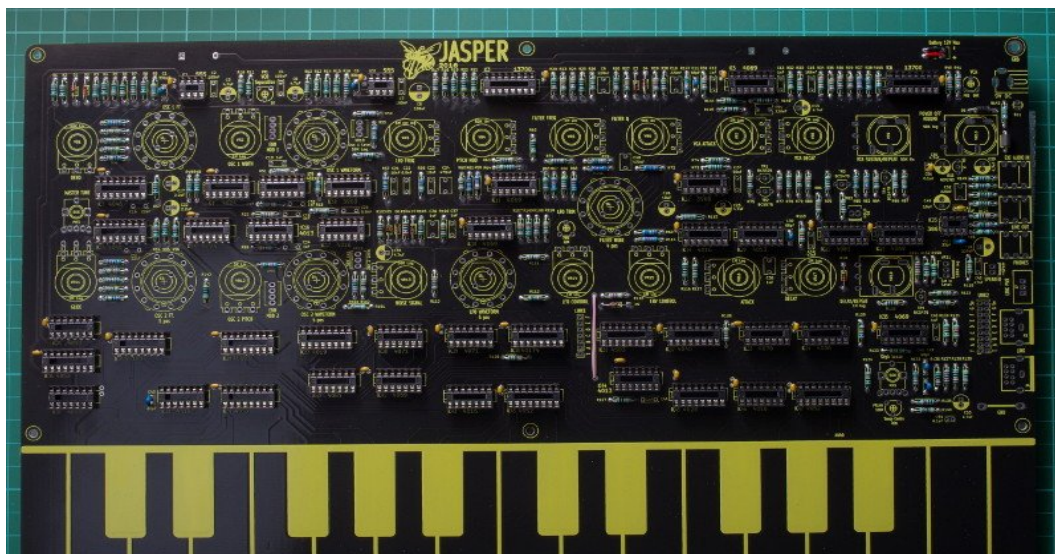

Most ICs will have a small decoupling capacitor close by. These are not marked with their component numbers. Use 0.1uF (100nF) ceramic capacitors with 2.5mm spaced pins. These were not used on the original Wasp – but are used to reduce switching noise on the power rail from the digital ICs.

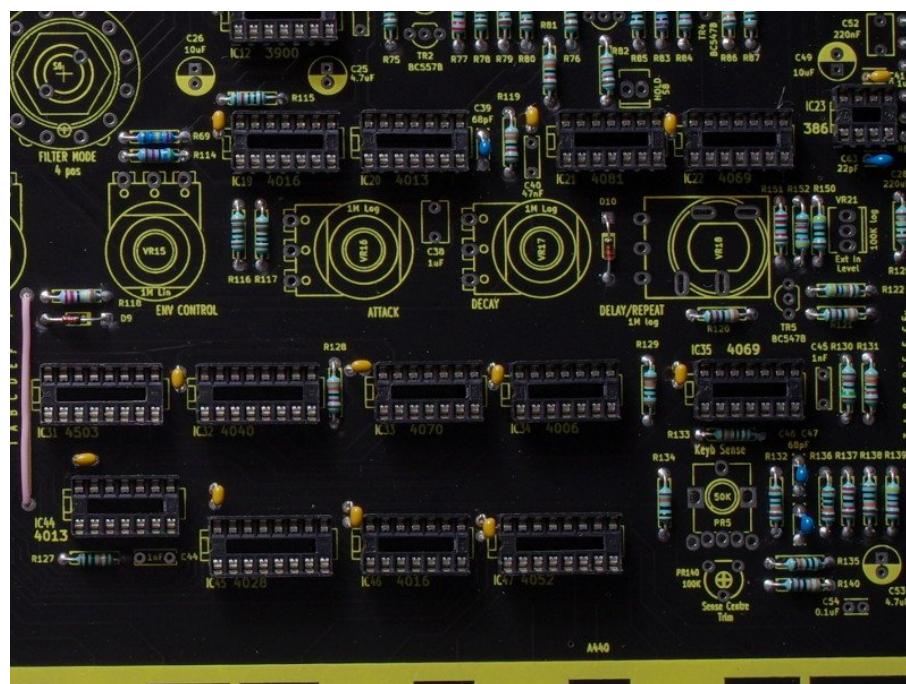

Box Capacitors, transistors, power regulator

When all the sockets are done, solder the slightly taller components – box capacitors, transistors, power regulator.

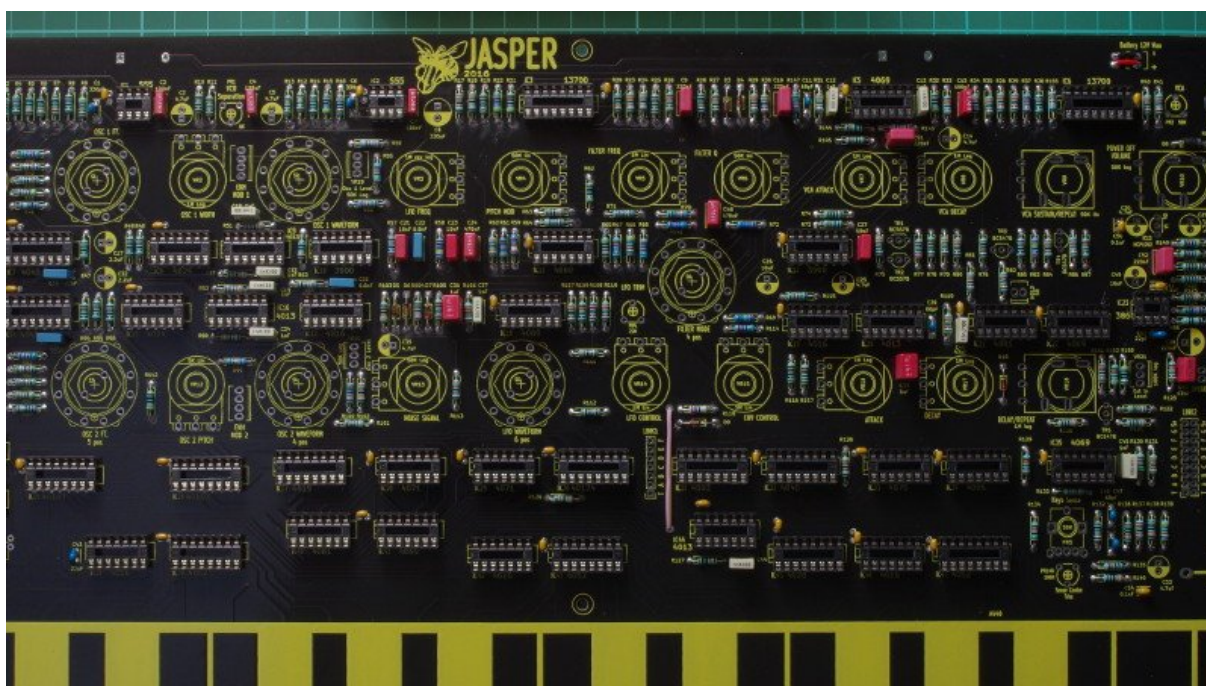

Ensure that the transistors are correctly aligned. The markings on the silkscreen are for BC547 or BC557 transistors. If you are using 2N3904 or 2N3906 transistors, turn them 180° to the silkscreen marking. If in doubt check the datasheet for the pinout.

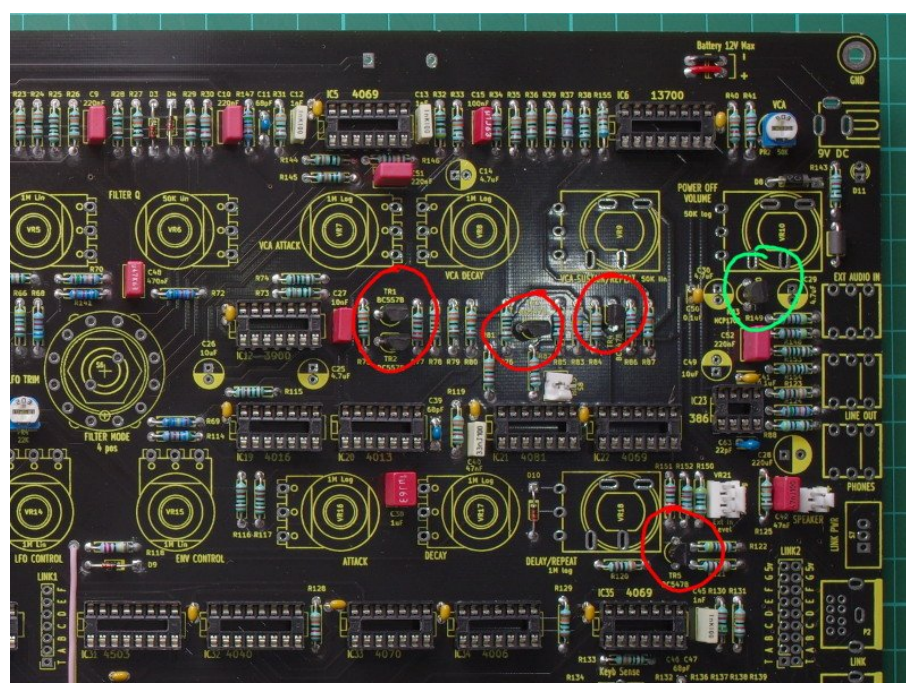

Do not get the voltage regulator MCP1702-5002 (IC13 – marked in green, above) mixed up with the transistors!

Trimmer potentiometers

Now solder the 6mm trimmer potentiometers.

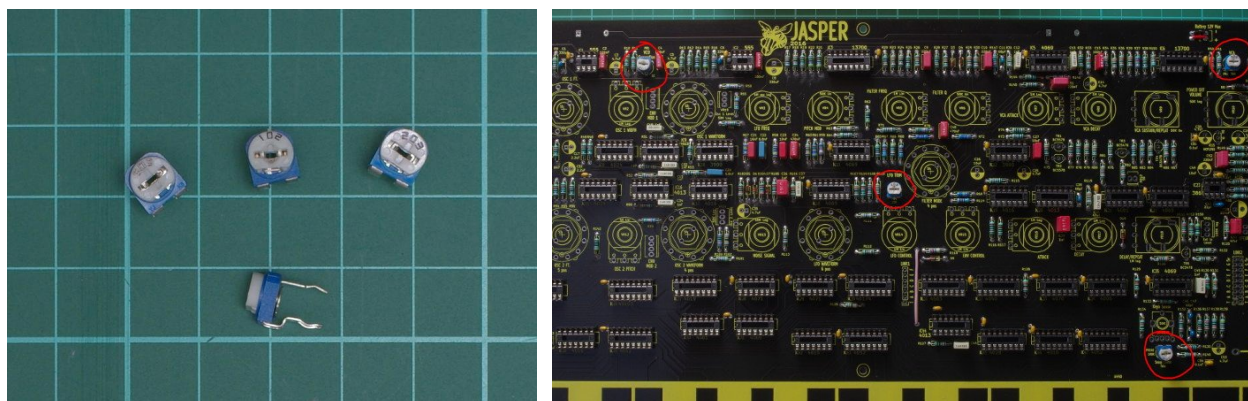

MTA100 PCB Headers

Next are the MTA-100 headers for the speaker, oscillator volume control, input control and enhanced waveform mods. To ensure they are flat on the PCB, solder only one pin first, then check if it is straight and remelt the solder if necessary to reposition it.

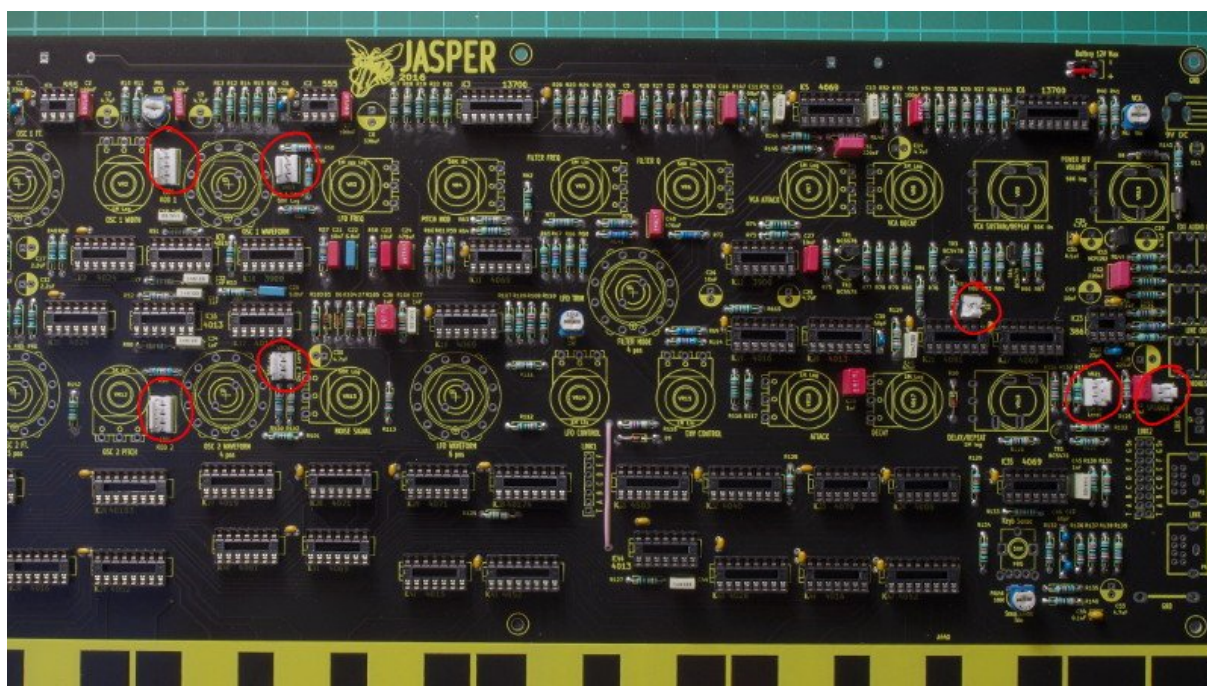

Note the orientation of the four pin Enhanced Mode headers – on the first revision of the PCB, place them opposite to the PCB legend. This is to allow for clearance when plugging in the Enhanced Mode PCB wires.

Use of MTA-100 headers are optional – it is perfectly OK to solder wires directly to the PCB. This step is best done later, after the controls have been soldered.

Electrolytic capacitors

Solder the electrolytic capacitors, ensure the correct polarity as marked on the silkscreen. The long positive leg of the capacitor should go on the square pad. The shorter negative leg, goes into the round pad in the painted half of the circle. The painted area shows the negative side, matching the line painted on the can of the capacitor.

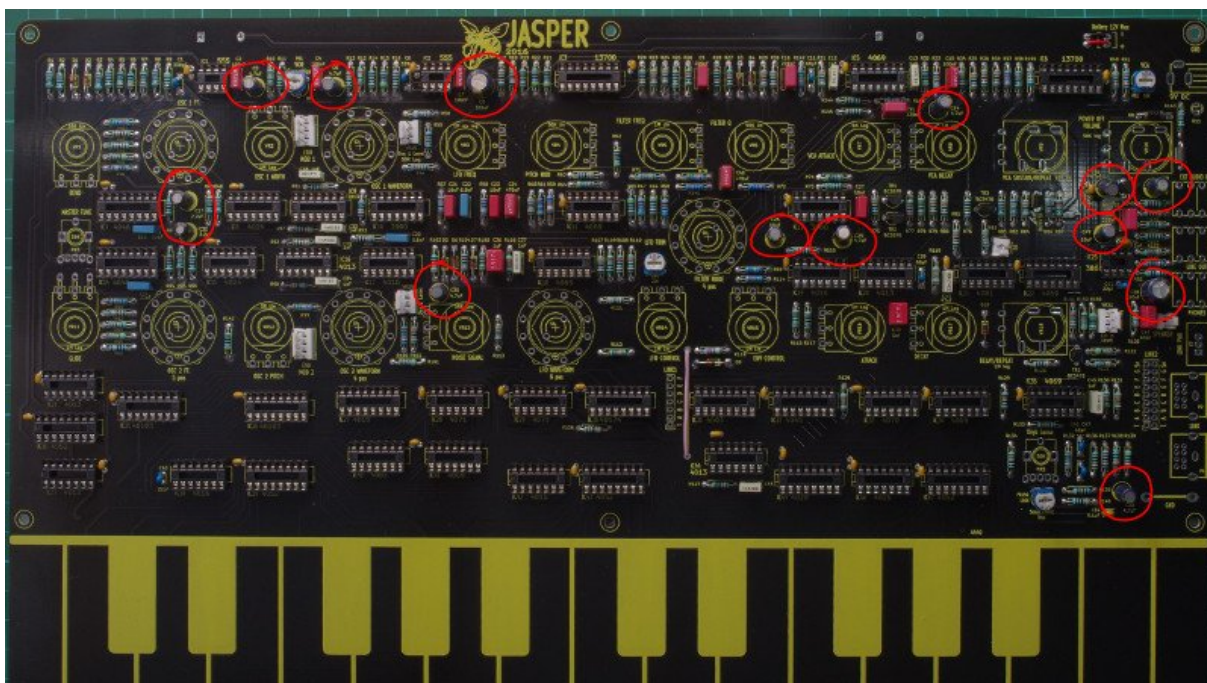

Jack and DIN Sockets

Solder the jack sockets and connectors on right-hand edge of the board.

Be very careful with the mini-din sockets as the data pins are very small. The small slide-switch for the power-over-link mod is optional – you can simply leave it out, or use a 3pin 2.54mm (0.1") header here.

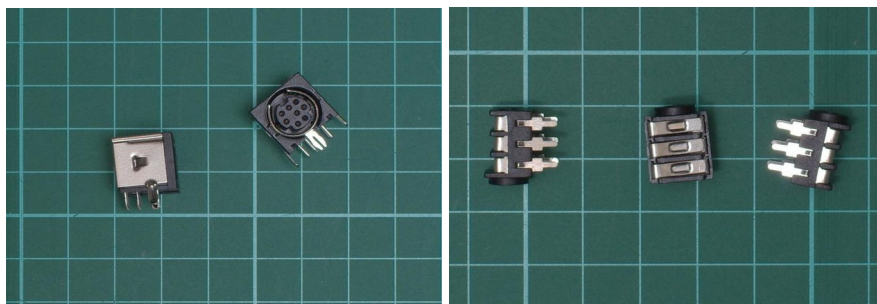

If you wish to use 1/4" sockets, you will need to solder wires to the 3.5mm socket pads for the larger jacks.

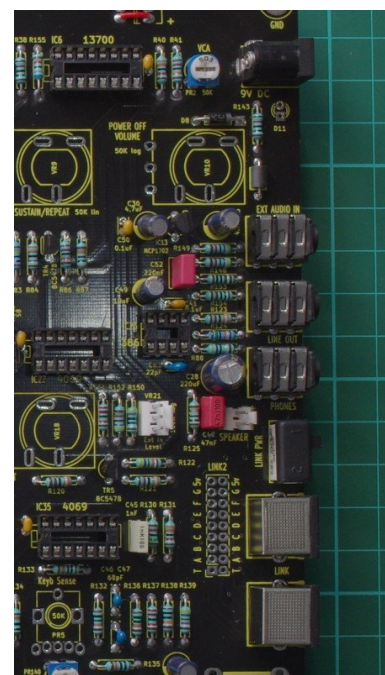

Link port cable

Cut a length of ribbon cable (or seven lengths of hookup wire) to connect the Link1 pads in the centre of the PCB to the Link2 pads at the right-hand side of the PCB. The ribbon cable is installed underneath the PCB for neatness, and soldered on the top side. Just make sure to solder to the lower 7 pads of the Link2 end, the remaining pads are for 5V and GND.

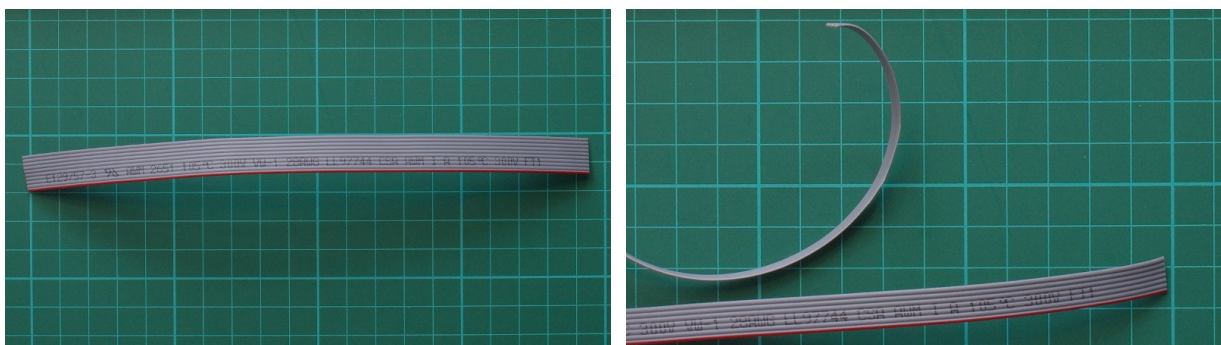

10 way ribbon cable with 3 wires peeled off leaving a 7 way cable

The spare row of pads at Link2 can be used for an internal MIDI adapter or for providing an additional Wasp compatible 7pin DIN socket. An MTA100 header will fit on the PCB (I used 3x 3way headers butted together).

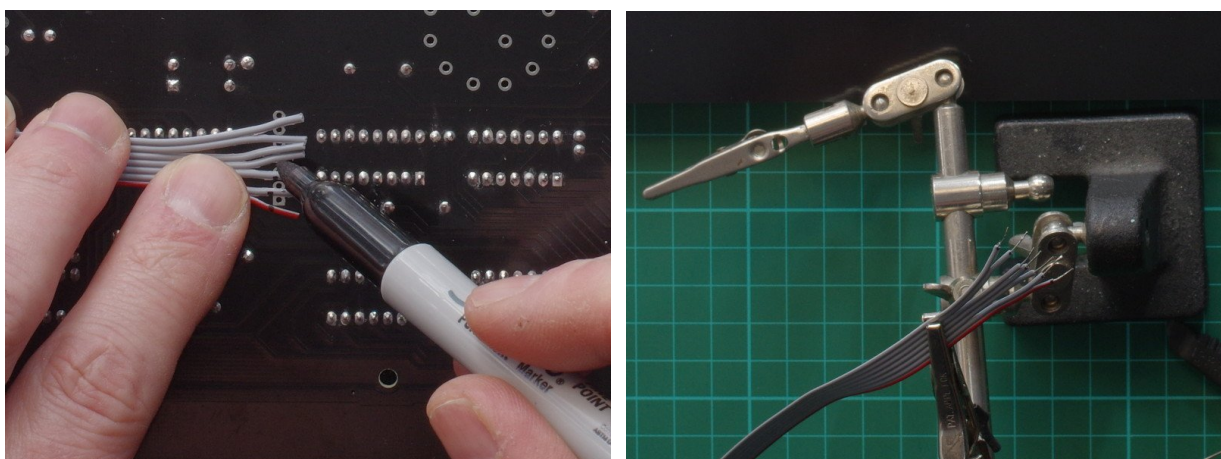

Conductors splayed and marked, then ends stripped and tinned...

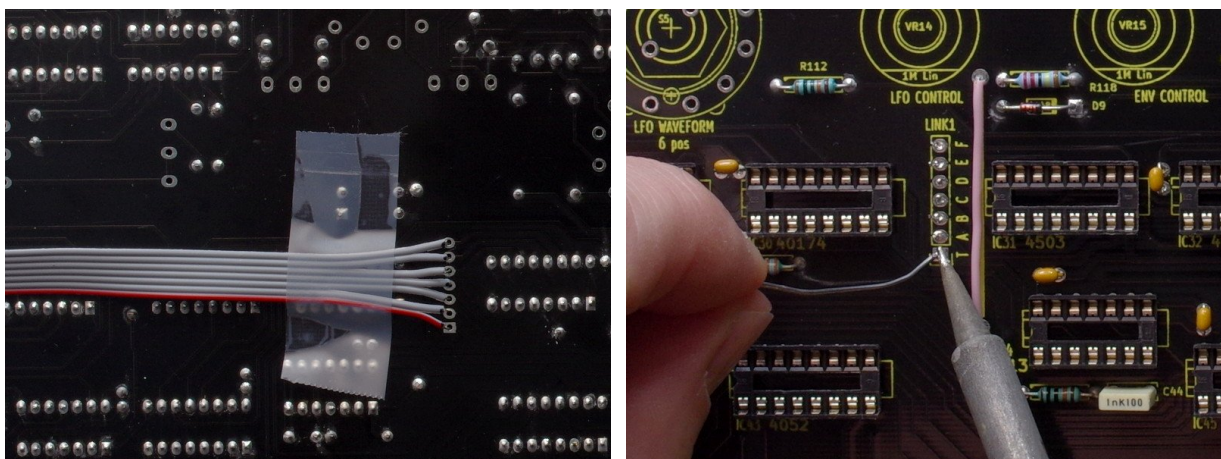

Held in place with tape, and soldered on the top side of the PCB

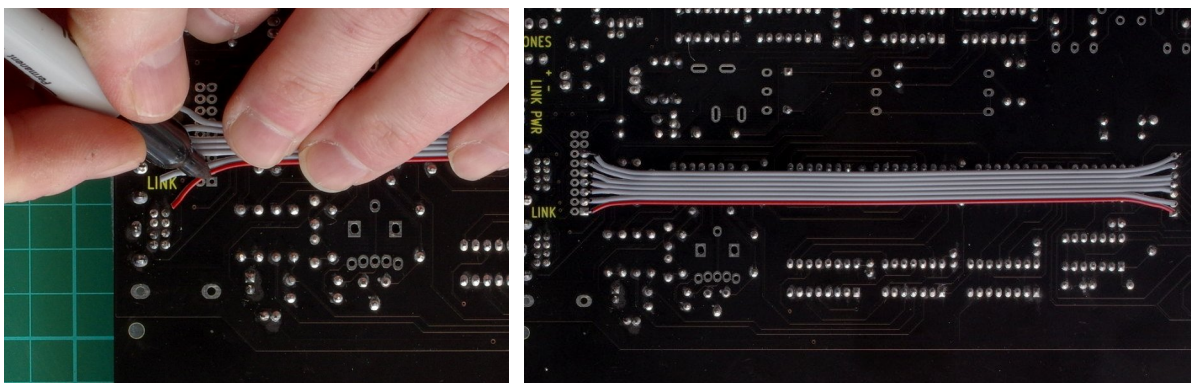

Repeat for the outer edge.

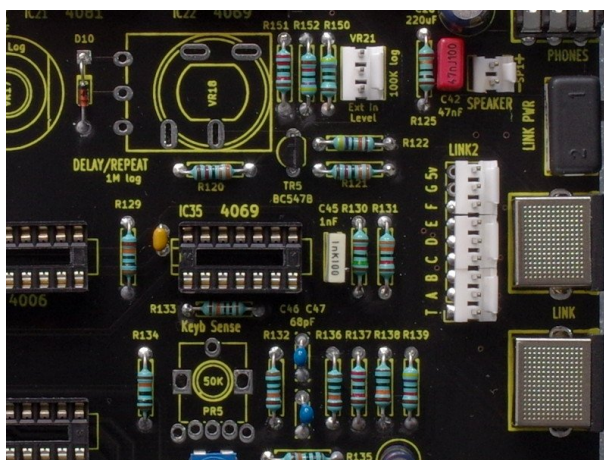

3-way x 3 MTA100 headers for internal Link bus

Panel Spacers

Fix the 6 x 17mm hex spacers onto the PCB using M3 screws from the reverse of the PCB. If you are using 16mm spacers, add two 0.5mm M3 washers between the spacer and PCB to build the height to 17mm to match the height of the switched pots..

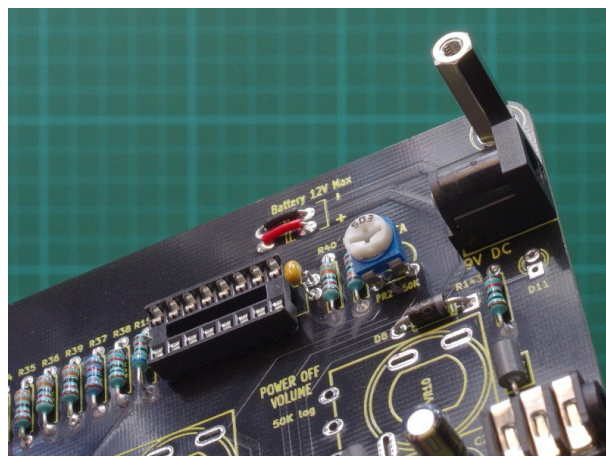
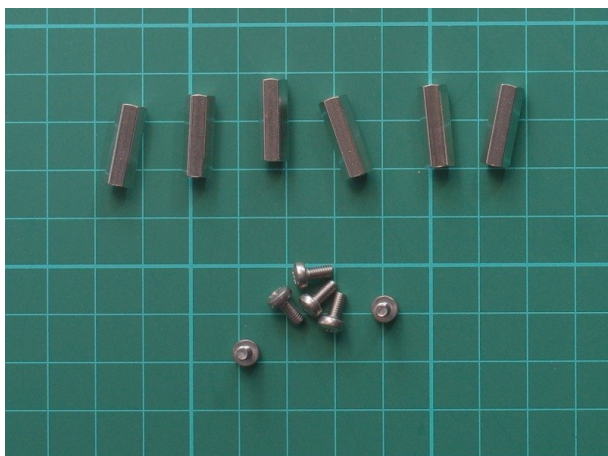

Switched Potentiometers

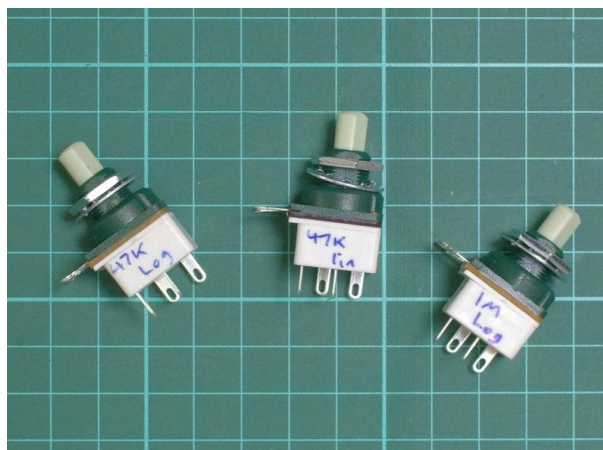

Prepare the switched potentiometers.

Cut nine lengths of tinned single core wire into 2cm or 3cm lengths – or use cut resistor leads.

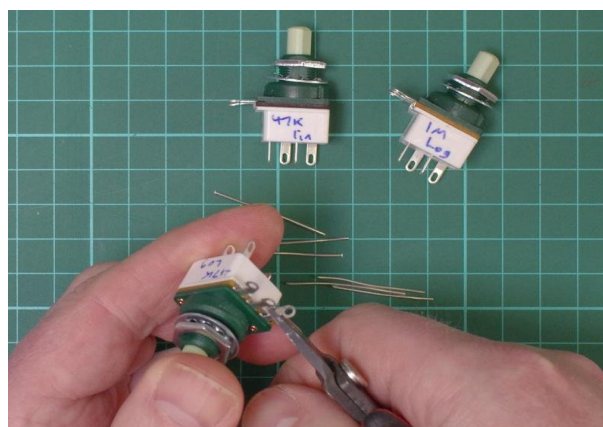
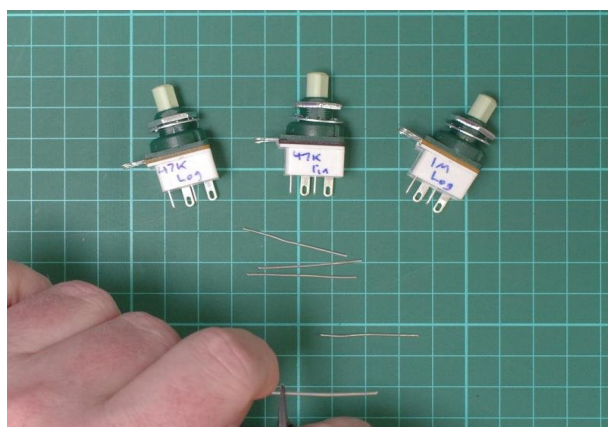

Carefully bend the potentiometer pins downwards with some small pliers. If the potentiometers have straight PCB pins, tin them with a little solder.

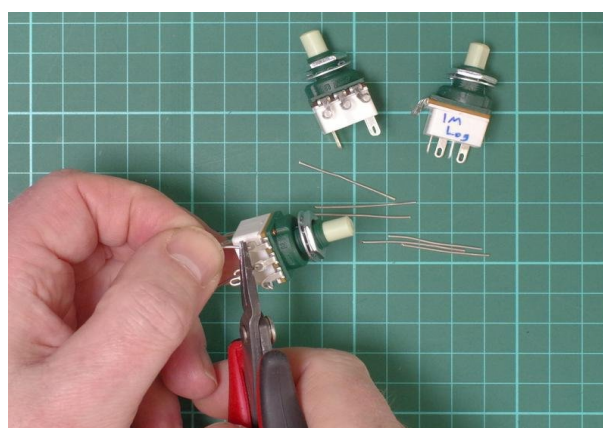
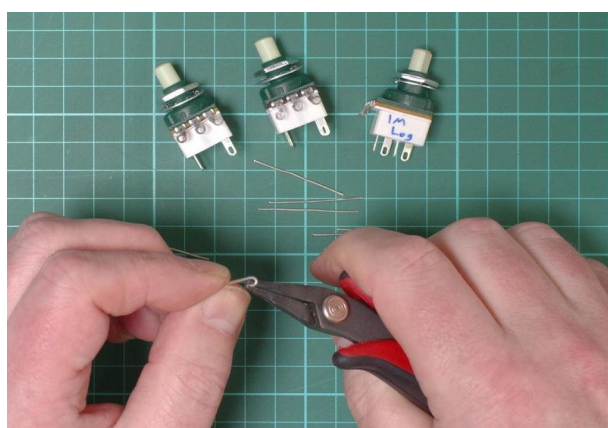

If you are using potentiometers with solder terminals, you may find it easier to make a small loop in the wire with pliers, and crimp it onto the solder terminals. The wires should point downwards parallel with the switch terminals.

Place the switched potentiometers onto the PCB, with the wires on the potentiometer pins pushing through the holes in the PCB. Make sure the base of the switch is pushed flush to the PCB

Jasper Synthesizer construction guide

surface. Ensure the potentiometers are in their correct positions. They all have different values. Place the panel over the switched pots and lightly screw the panel onto the hex spacers.

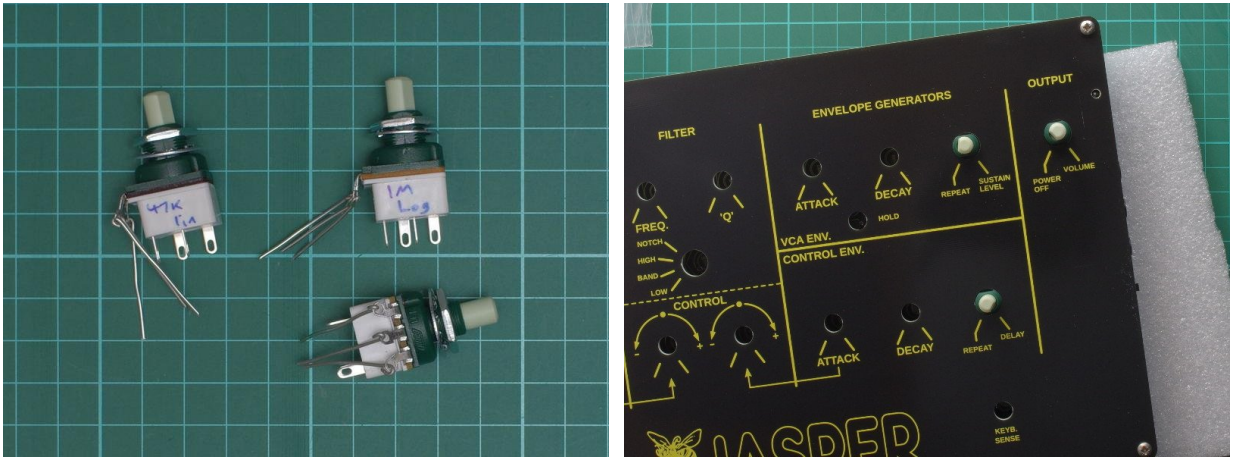

Solder the pots and switch contacts on the underside of the PCB.

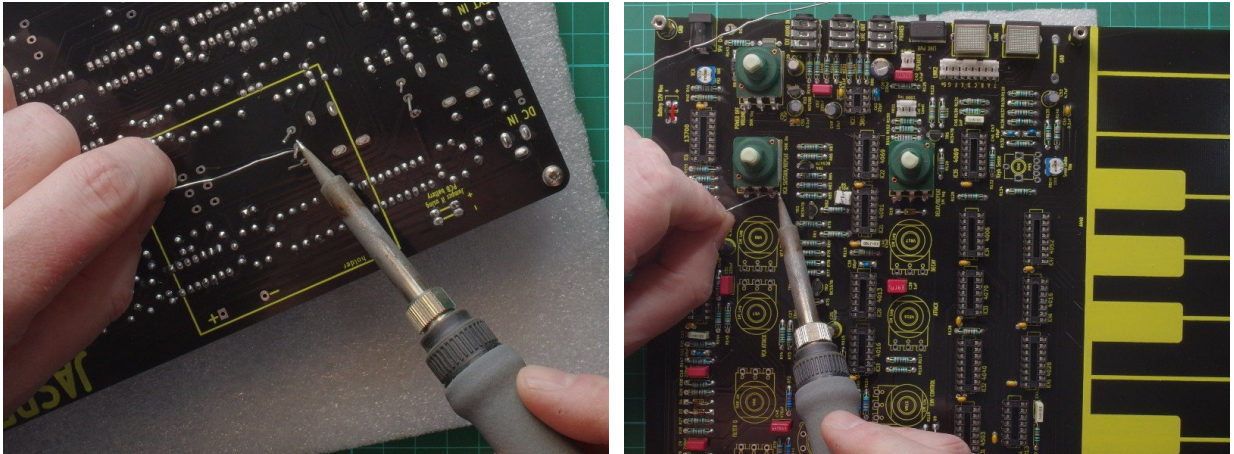

Solder the lengths of single core tinned copper wire onto the potentiometer pins.

Rotary Switches



If your rotary switches have long shafts, cut them to size before placing them on the PCB. Leave the nut and washer on the switch, as this will be below the control panel and acts as a spacer.

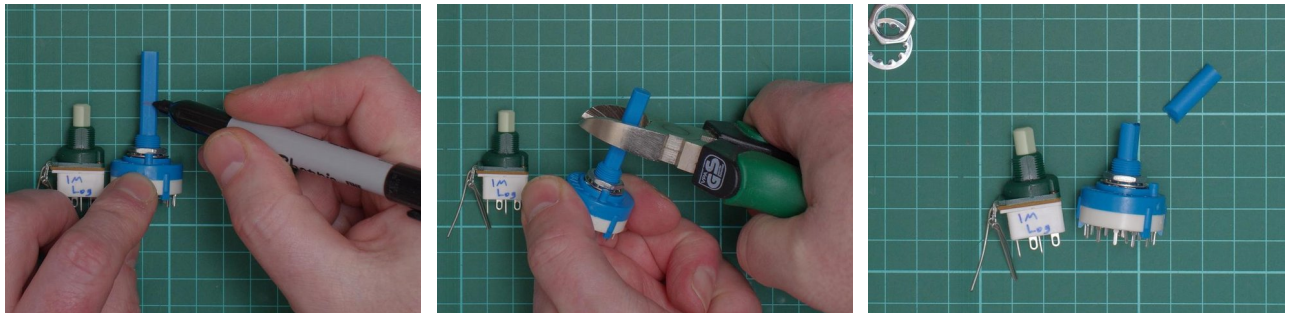

Line up the top of the switch's nut with the shoulder of a switched pot. Make a mark on the shaft lined up with the top of shaft of the switched pot. With some hefty pliers cut the shaft. The plastic is fairly soft. The top will be rough, but don't worry as this will be covered by the knob.



Make sure the pins are straight.

Place the switches into the correct spaces onto the PCB. The pins are a fairly tight fit – and you may need to straighten the pins before they will fit through their holes in the PCB. Seat the rotary switches so they are flat on the PCB – the small moulded stand-offs on the switches will hold their base slightly off the PCB surface.

Jasper Synthesizer construction guide

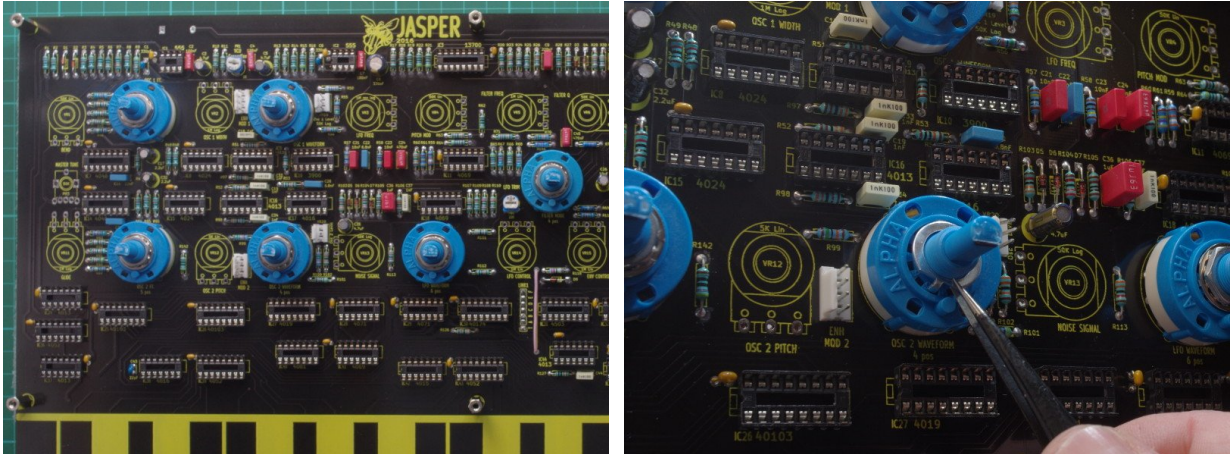

Remove the nut and serrated washer of each rotary switch. Underneath is a small keyed washer that sets the number of positions. Set these to the correct positions – remove the keyed washer, and replace it so the key is in the correct hole for the number of switch positions. Once set, check the number of clicks before the stop. The number of clicks is one less than the number of positions needed as indicated on the PCB.

Place the serrated washer on the keyed washer, and screw on the nut.

Put the panel over the switches and screw it down onto the hex spacers using M3 screws

The rotary switch bushings will poke through the PCB. Make sure they're straight. If you have spare nuts that fit the rotary switches, hand tighten these so they are pulled against the panel.

With luck everything is lined up – you may need to jiggle things about a bit so the panel rests flat. Double-check all the pins are pushed into the holes into the PCB, and solder them up.

When soldered, unscrew and remove the top panel from the hex spacers.

Preparing the 16mm Potentiometers

Prepare the 16mm potentiometers. This process is needed so the pots are the same height as the rotary switches. You will need a pair of thin-nosed pliers.

Break off the locating lug off the face of each potentiometer with the pliers. This is so they can be attached flush against the front panel.

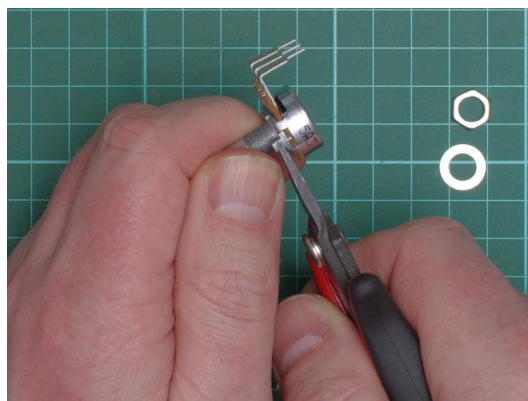

Vertical mount PCB potentiometers: straighten the legs of the potentiometers with pliers so they are taller.

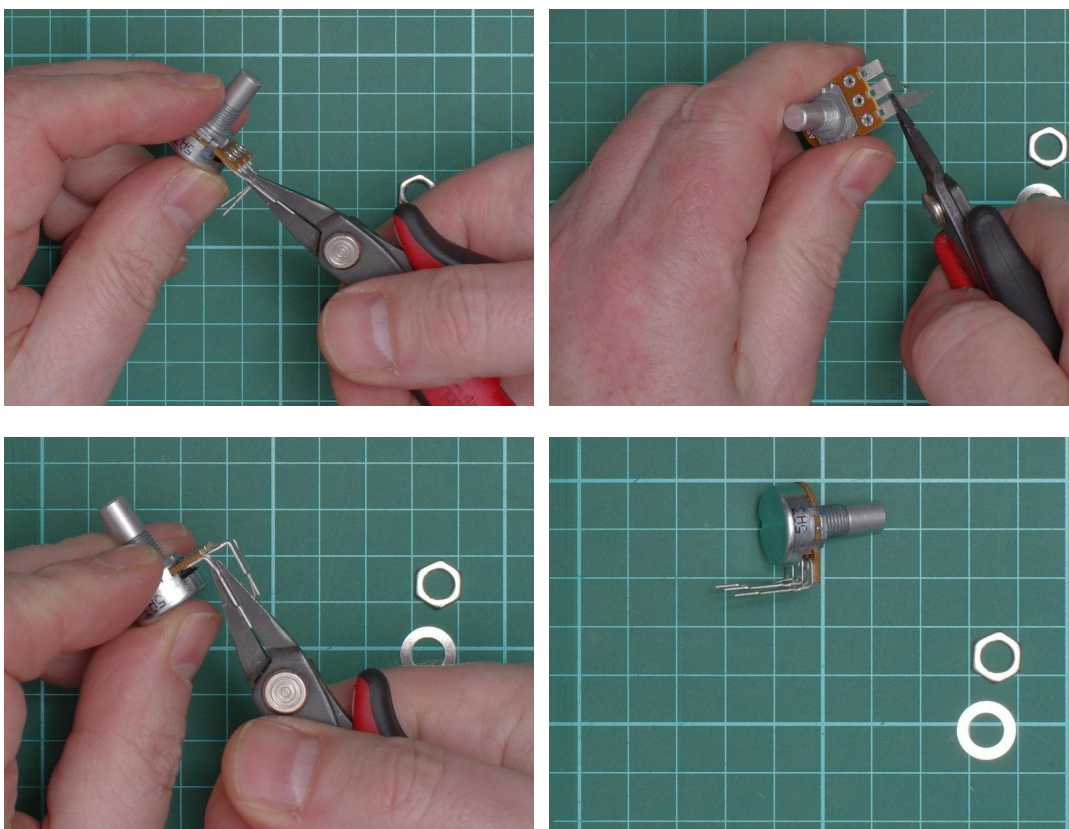

Potentiometers with solder lugs: If you have pots with solder lugs or pins, solder thick solid core wire onto each pin to allow them to be mounted vertically onto the PCB. Use lengths of wire about 30mm in length. 20SWG wire is good for this; cut component leads are really too thin for this job, as the pots will rotate when tightened up to the panel. It really is necessary to use the thicker wire.

You can use a breadboard or stripboard to help line the pins up.

Jasper Synthesizer construction guide

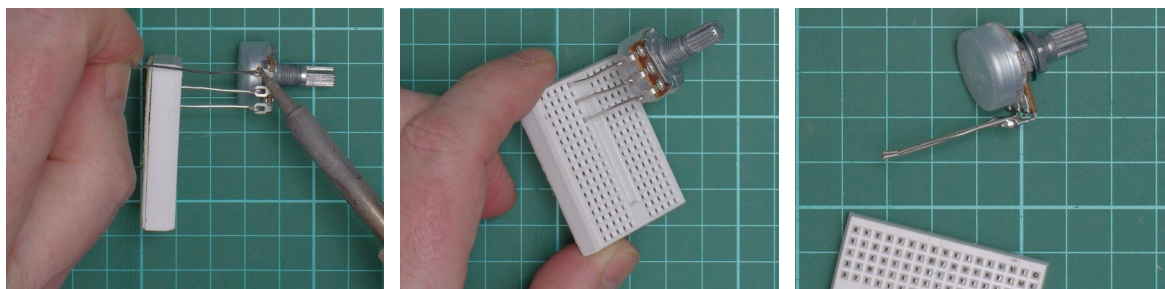
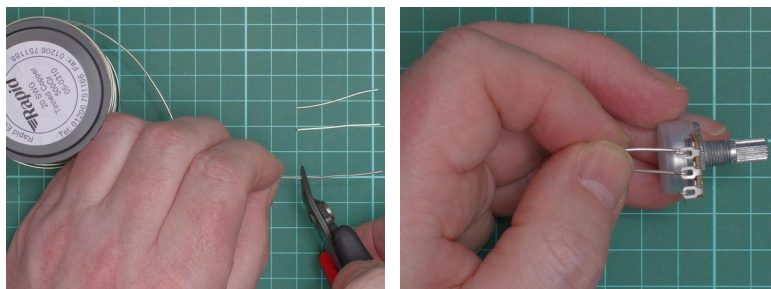

Dual A1M potentiometer – Glide: If the pot has solder lugs, straighten up the upper 3 lugs. Form 3 lengths of single core wire into 30mm lengths and a hook or loop at one end. These hook over the pins or lugs to connect to the PCB.

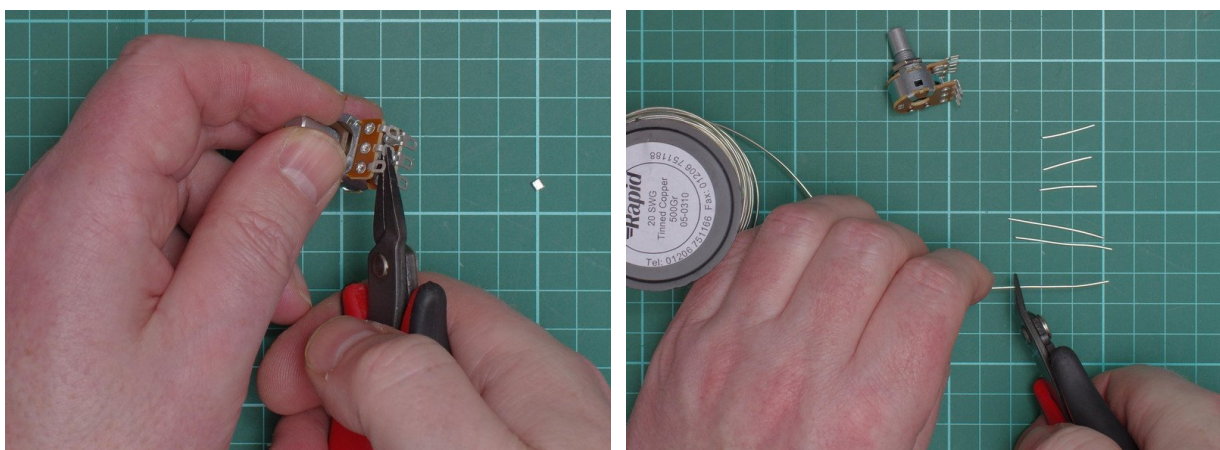

The lower pins/lugs require short lengths of wire to enable them to be soldered to the PCB. Use lengths about 15mm long with a hook or loop at the end to hook over the lugs. Solder all the wires so they're all parallel.

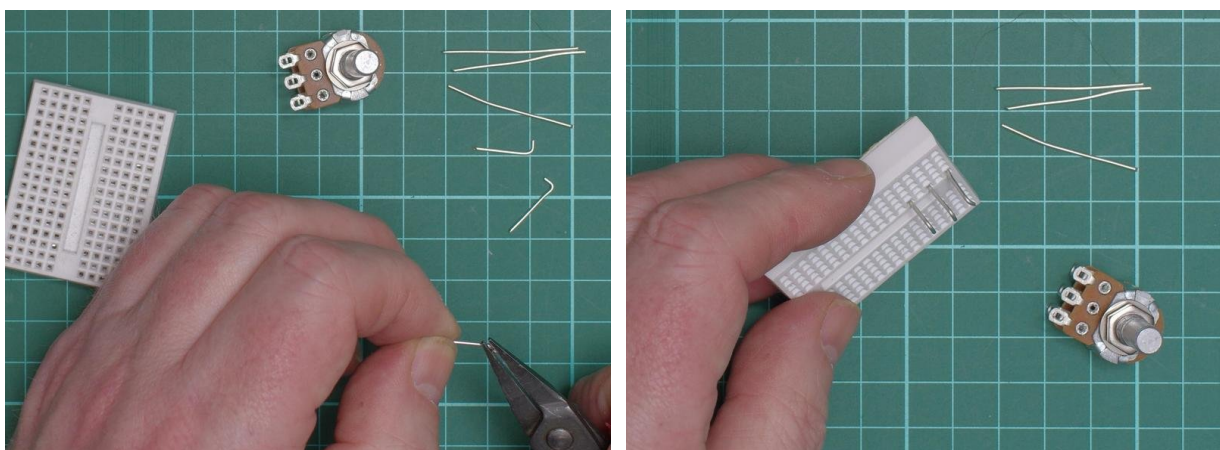

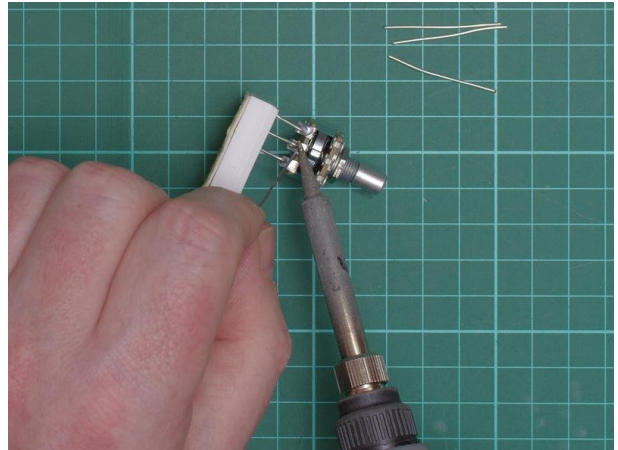
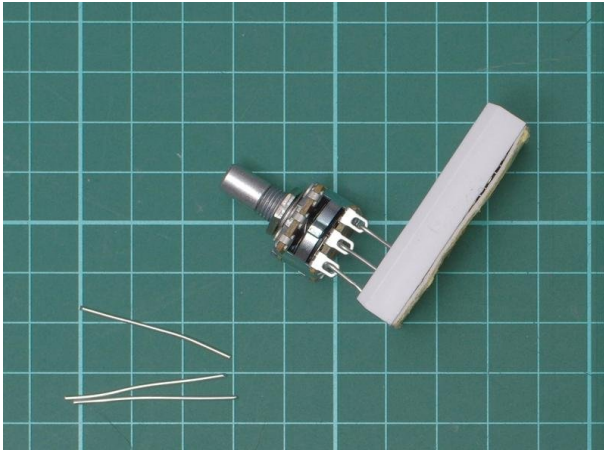

You may want to fit the wires into a breadboard or stripboard while you solder them to the potentiometer to help the alignment.

Next make small hooks in the longer wires and place them over the upper solder terminals and insert them into the breadboard in line with the lower pins.

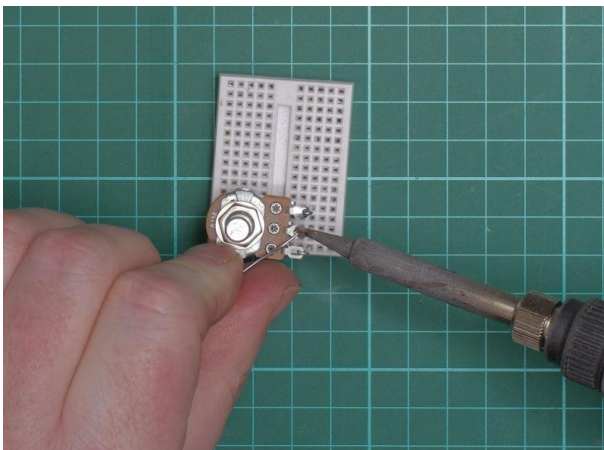
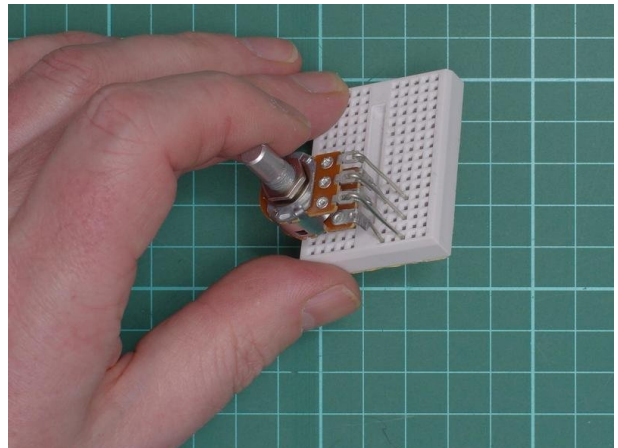
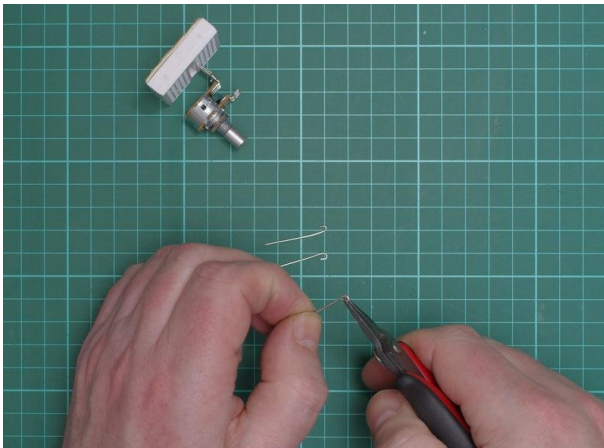

Keyboard sense and Tune pots

Place the long shaft 9mm potentiometers onto the PCB. The side pins will clip into place – but you may need to straighten them up with pliers before they fit. If using the Piher trimmers, clip the shaft into the trimmer base, and place the trimmers onto the PCB.

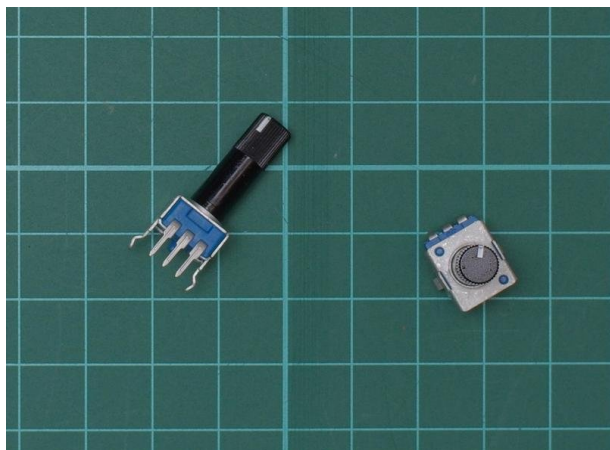

OR

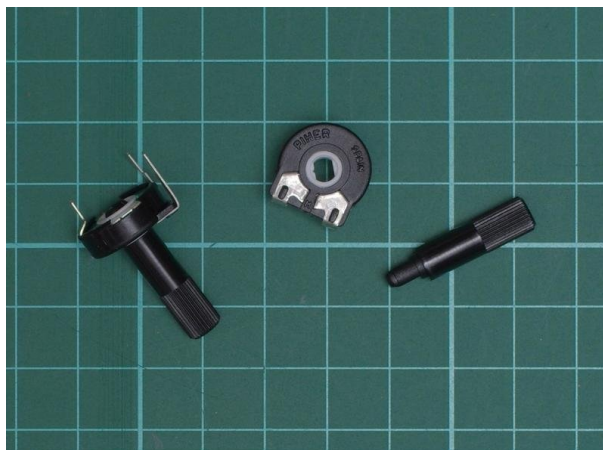

Soldering the Potentiometers

Start placing the other pots onto the PCB, and put the panel on. Make sure it is flat and level - tighten the nuts to fix the pots to the panel, so they are correctly aligned. Make sure the pins stay in their PCB holes and the panel is flush on the switches and hex spacers. Before soldering the pots screw down the panel onto the hex spacers.

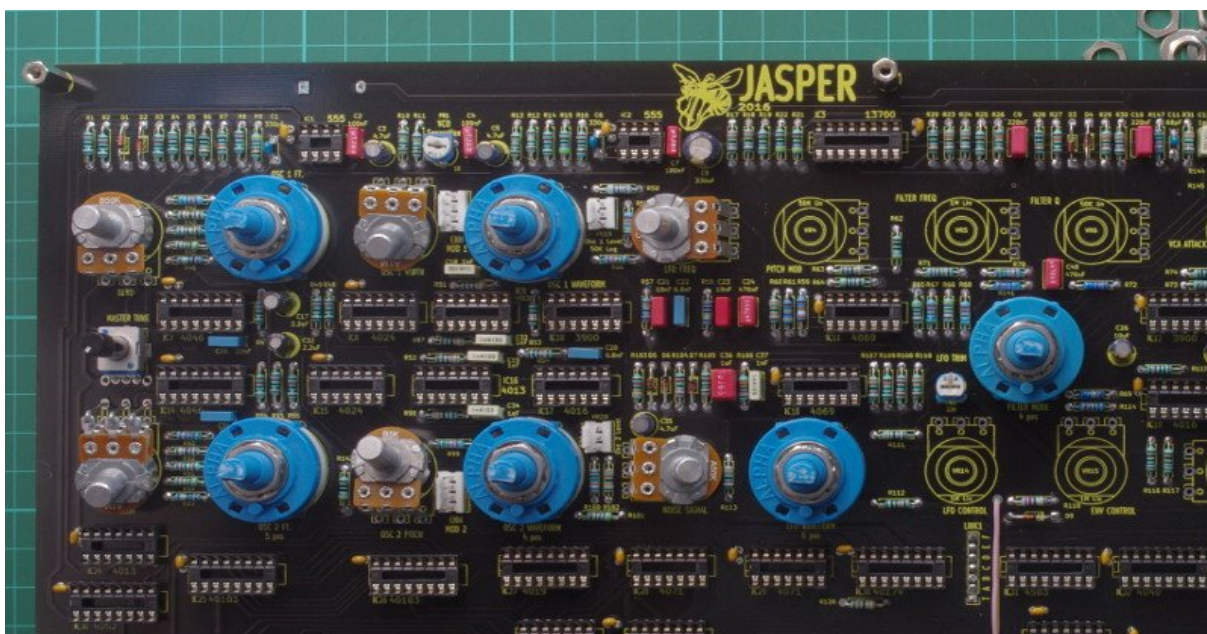

It can be tricky to get everything lined up all at once – so work on a few pots at a time. Make sure the panel is flat, and the pot pins go through the pads on the PCB.

Jasper Synthesizer construction guide

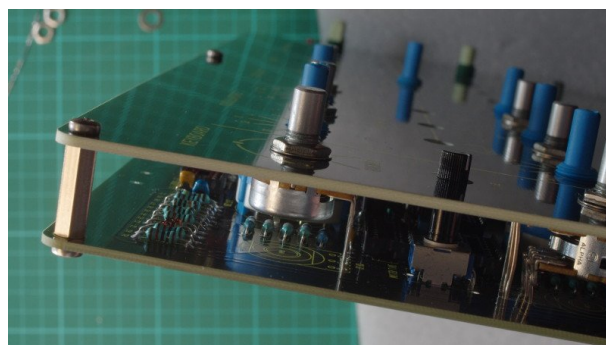

The Tune and Sense potentiometer shafts should fit through the holes in the panel without snagging on the edges. Straighten them up if necessary.

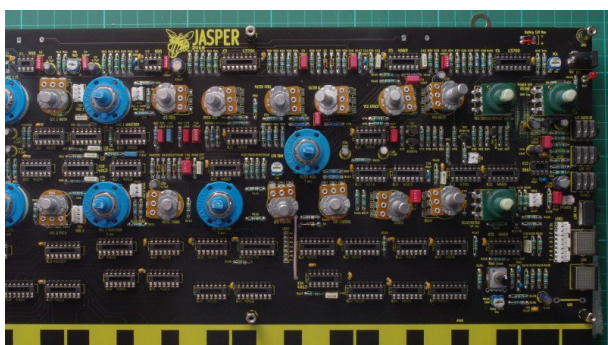

Also fit the power LED so it pokes through the hole in the top panel. The LED's long lead goes to the square pad on the PCB.

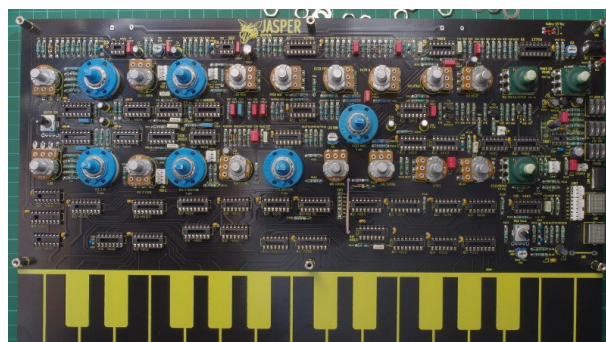
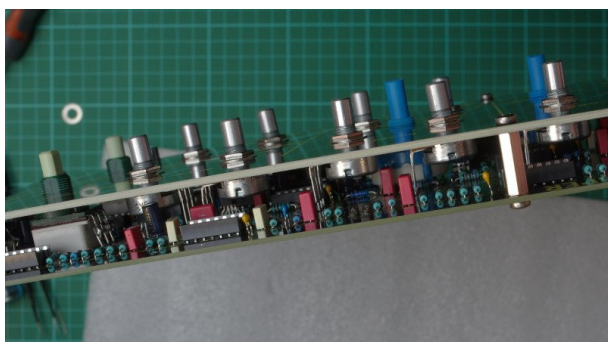

When everything is soldered, remove the nut from each pot, and remove the top panel.

Panel Mounted Controls – 9mm Mix Potentiometers and Hold Switch

The 9mm potentiometers oscillator and input volume need to be prepared. If the pots have a small anti-rotation lug, remove first with pliers or snips.

Oscillator 1 and 2 volume controls: solder wires to the three terminals of the 50K log pots. Use fairly generous lengths of wire – they will be trimmed later.

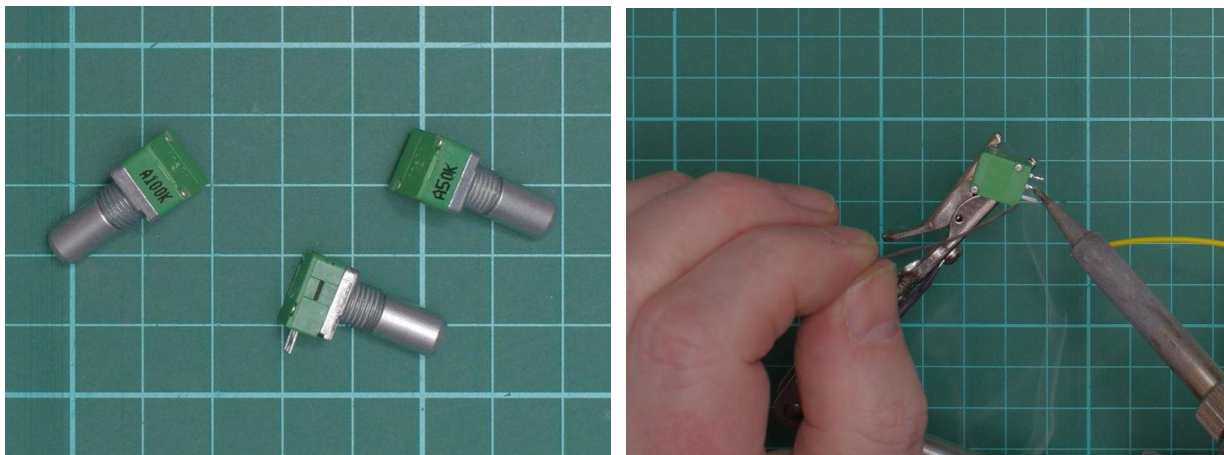

The 9mm pots – carefully tin the pins with a little solder

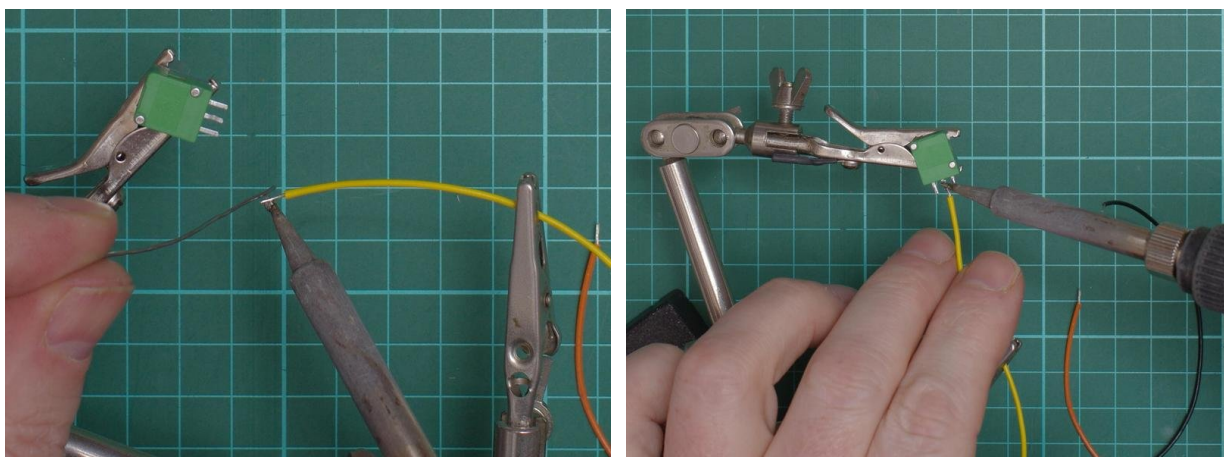

Strip and tin each lead – and solder to first lead to the potentiometer pin

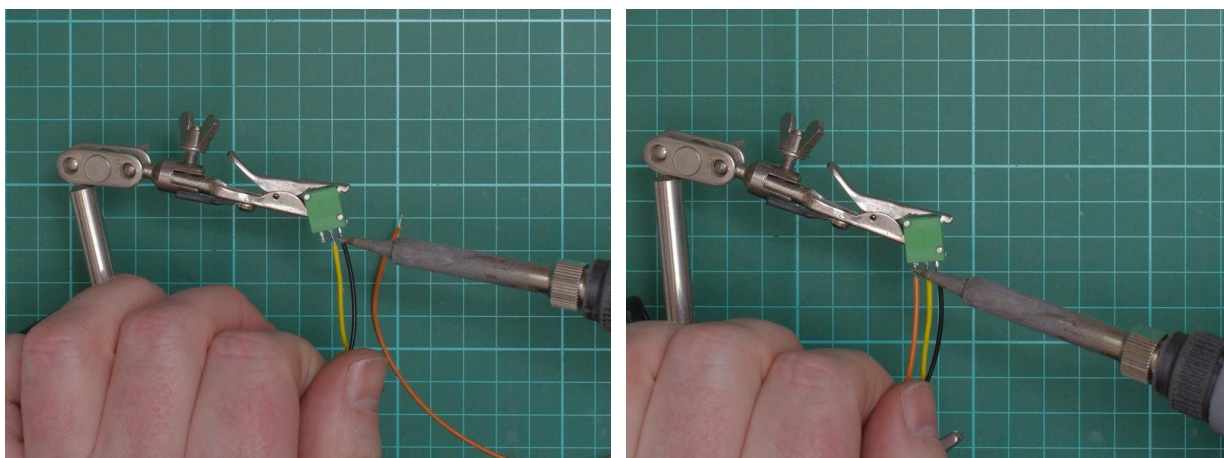

Solder the remaining leads

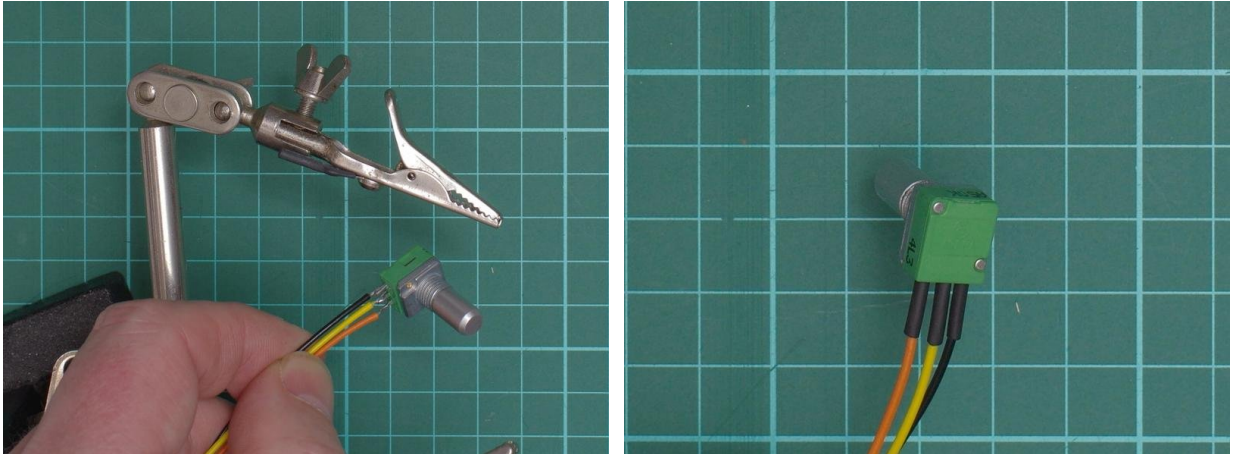

Use a little heat-shrink tubing to protect the solder joints

Heat-shrink tubing can be used to hold the three wires of each pot together.

External input pot: only solder 2 wires to the pot – this is used as a variable resistor in the gain circuit of the input amplifier. A third wire, or shielded twin wire can be used, as there is a 3 pin header on the PCB – the third conductor is for a shield or gnd wire. If using a single wire, wrap it around the two signal wires, but don't solder it to the potentiometer.

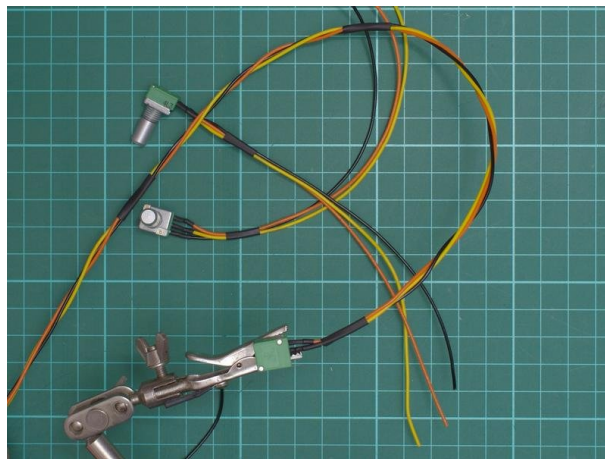

For the external input pot, only connect two wires.

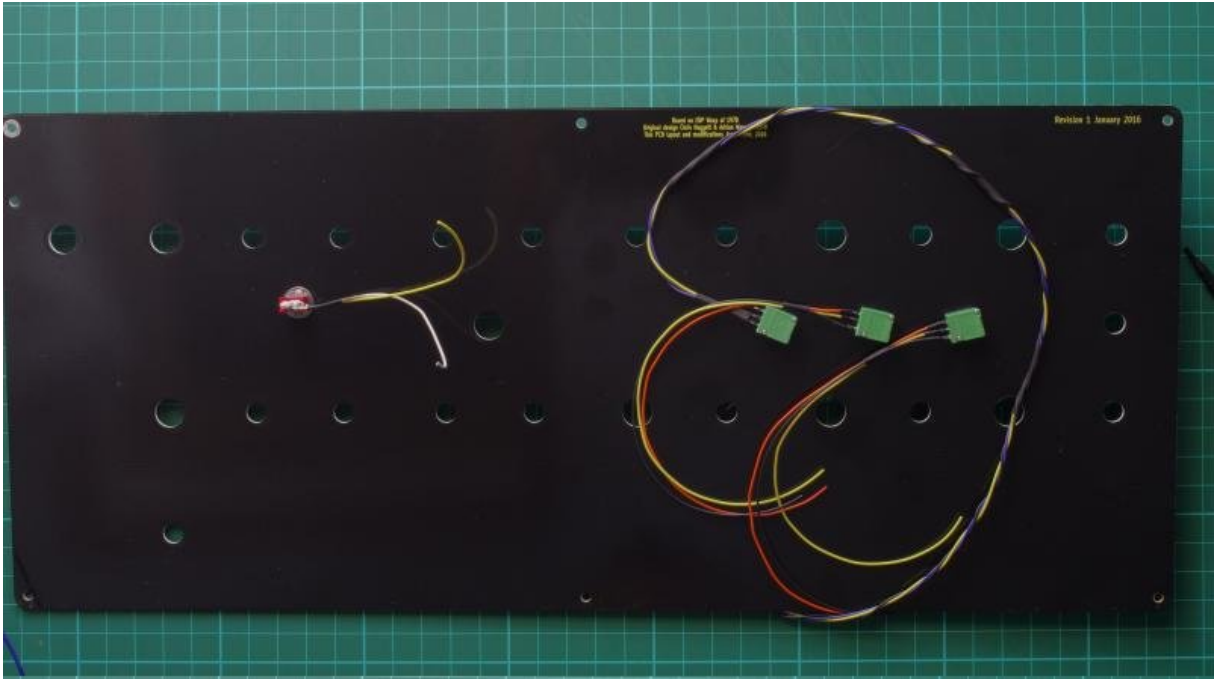

The controls are mounted onto the panel – offer the panel up to the main PCB and trim the wires to length.

The Hold switch is a sub-miniature On-Off SPST or On-On SPDT switch with two pins used. A switch with PCB pins is best as it is possible to solder the wires close to the body of the switch, and the pins trimmed as to not short out on the components on the PCB. If you are using a SPDT switch, clip the unused pin.

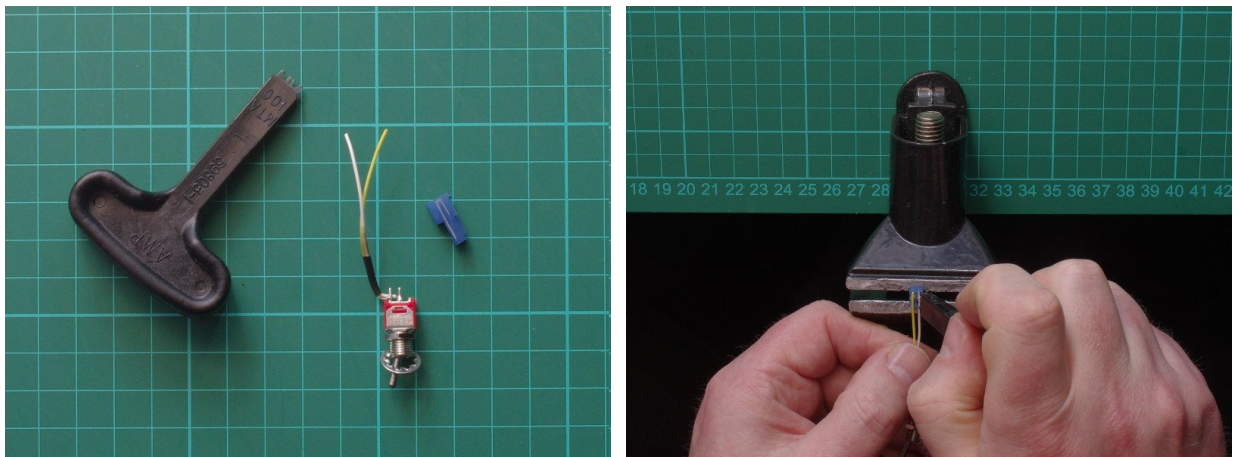

Using an MTA100 punch tool, with the help of a small bench-vice punch the pot and switch wires onto the plug.

Jasper Synthesizer construction guide

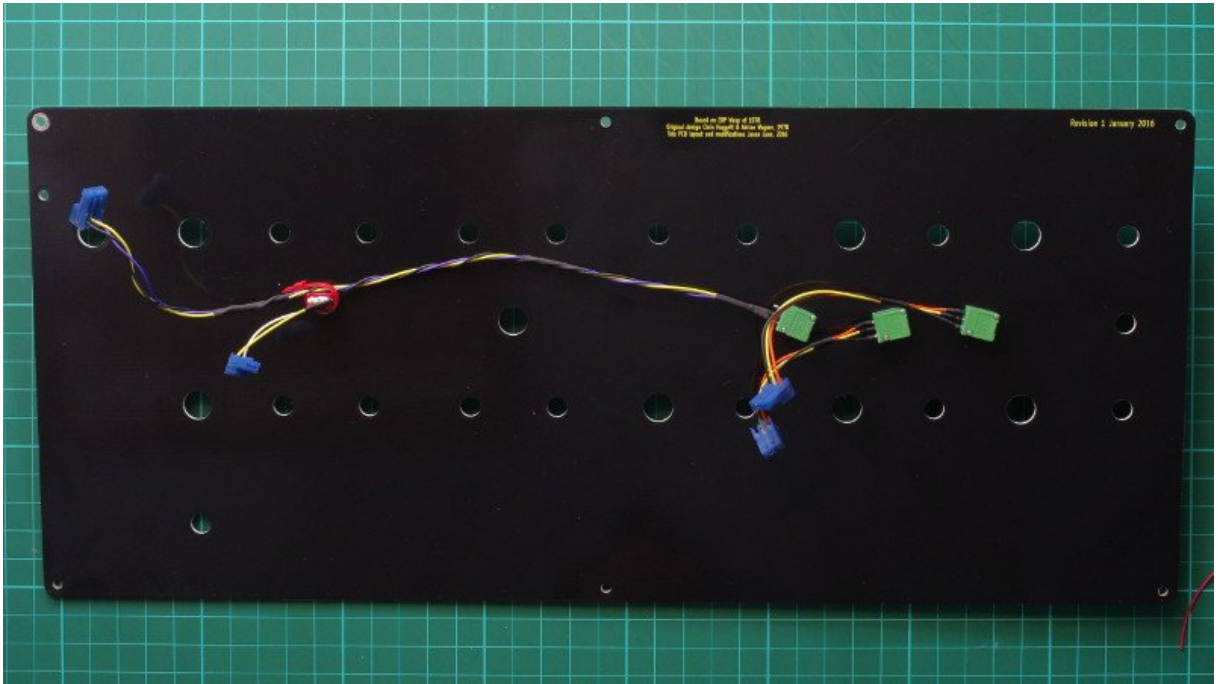

The pots and switches can be carefully plugged into the PCB when you assemble the panel. Make sure the wires don't snag on the pots and switches.

First power up test

Before installing the ICs, we will do a basic power test.

Look over the soldering, and check for missing or bad solder joints, or solder bridges. If in doubt reflow the solder by heating the pin again until the solder melts. Check polarity of the electrolytic capacitors and diodes.

Connect a 9V battery or DC power supply to the 2.1mm DC socket – centre pin is positive. If you are using a bench supply, limit the current to about 200mA. Turn the volume control so it switches the power on. The power LED should light – if not check the voltage regulator, and/or polarity of the LED. Check for 5V on the IC sockets. If there is no voltage check the battery, and for short circuits between 5V and 0V. Check the regulator – make sure it is oriented correctly.

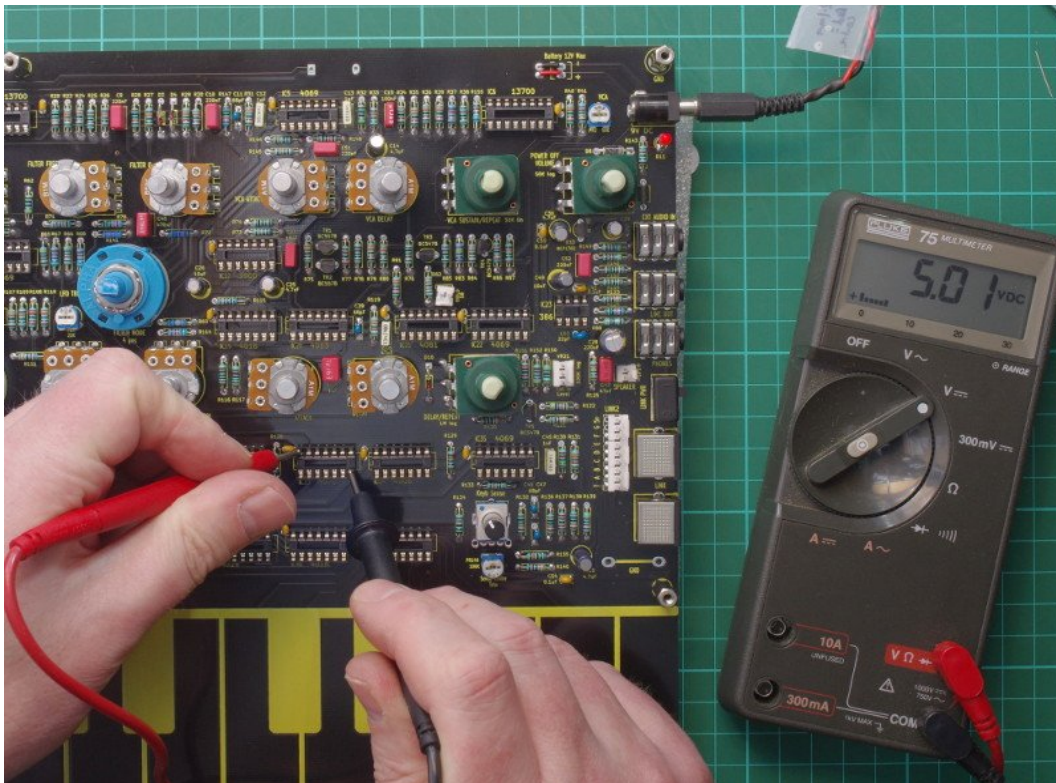

Install the ICs

Remove the power. Ground yourself to protect against static electricity, and install all the ICs. You will probably need to straighten the legs of the chips so they fit in the sockets. An IC pin straightening tool is very useful here, though it's possible to push the sides of the chip against your workbench to straighten the pins. When inserting the ICs into their sockets ensure the pins don't get broken or bent underneath. And double-check the number of each IC as you insert them.

Battery holders

If you are using them, the battery holders fit underneath the PCB and can act as a stand for the synth. If you are using a basic laser-cut base plate, they fit through openings in the baseplate. It is a good idea to offer up the baseplate before soldering the battery holders. Use sticky foam pads to hold the battery holders in place.

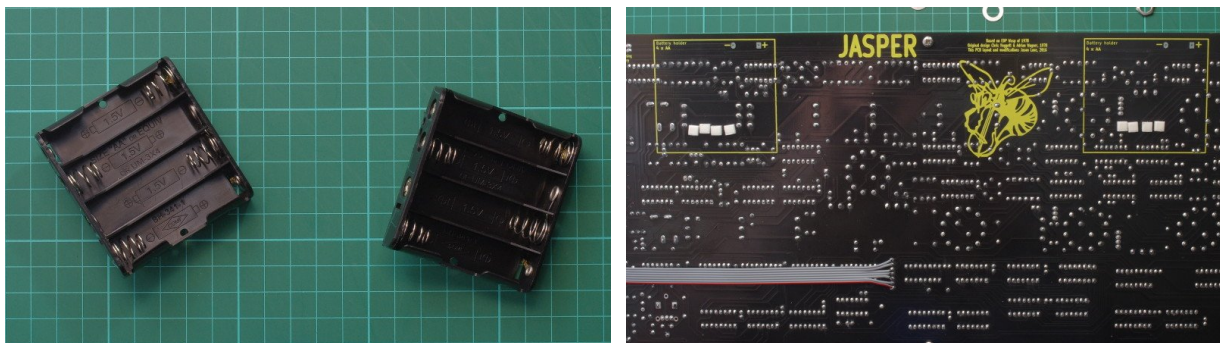

AA battery holders – held in place using double-sided adhesive foam pads

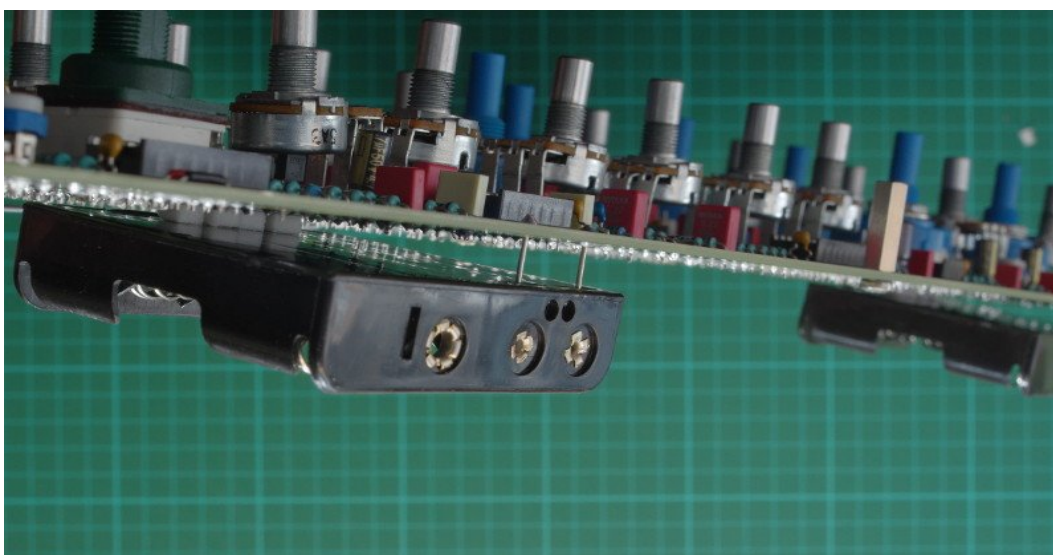

With a simple lasercut enclosure, One-Wrap Velcro strips can be used to keep the batteries in place, and help protect the tabletop.

Speaker

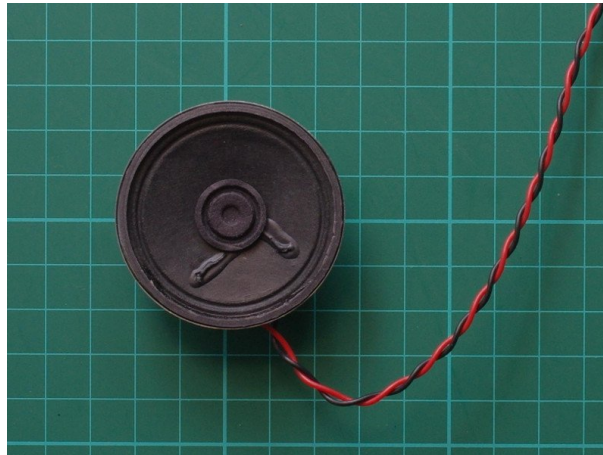

Make up a pair of wires connected to your speaker – it is a good idea to use red wire for the +ve terminal, and black for -ve. Make sure the wire is long enough to reach the speaker's mounting in your enclosure. If testing, a loose small 8Ω speaker will do.

If you are not using a speaker, you can put a 47Ω resistor across the speaker header pads, so the amplified 'phones' output will work on both channels of the jack socket.

If you don't want to have the 'Phones output, then you could leave out the LM386 amplifier and phones jack completely.

Enhanced Mode PCB

Prepare the Enhanced mode PCB as per its build guide. Prepare the wires to the correct lengths to get to the PCB from where you intend to mount the PCB, and attach the wires to the MTA100 connectors. The wires could also be soldered directly to the main PCB.

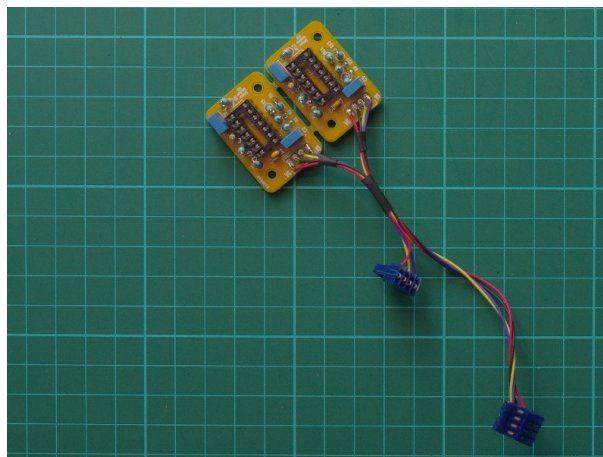

Testing and setup

For testing and initial setup, remove the panel. As Jasper won't have its knobs yet, mark the tops of the pot shafts using a pen with an indicator line. Turn each pot fully anti-clockwise (off), and make lines to mark the off positions.

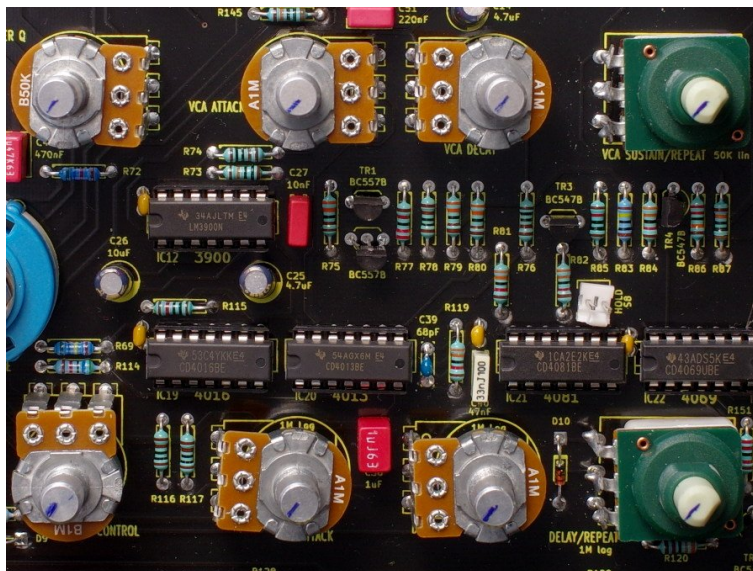

Jumper the top two pins of each of the oscillator volume pots headers. This sends the maximum volume of the oscillators to the filter.

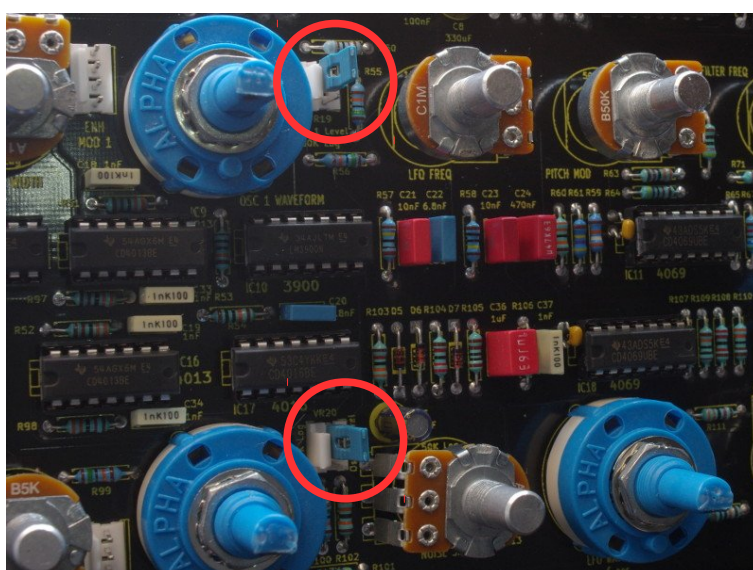

Initial control setup

Set the controls for the initial setup – this is a sort of ‘home’ configuration:

- Bend: Centre
- Glide: Off – fully anti-clockwise
- Osc1 & Osc2 octave: 8FT or 2 stops from anti-clockwise
- Osc1 Width: On – Fully clockwise
- Osc2 Tune: Off
- Osc1 & Osc2 Waveform: Sawtooth – one stop from Off.
- Control Osc Freq: Off
- Pitch Mod Off
- Noise Level Off
- Control Osc Waveform: ‘Sine’/Triangle – fully anti-clockwise
- Filter Freq: On – Fully clockwise
- Filter Q: Off
- Filter Mode: Off
- LFO Control Centre
- VCA Control Centre
- VCA Attack Off
- VCA Decay Off
- VCF Attack Off
- VCF Decay Off
- VCA Repeat/Sustain On
- VCF Repeat/Delay Minimum after switch clicks
- On/Volume On, half volume

Power

Plug in a 9V power adapter or battery into the DC socket.

Switch the power on – the LED should light.

Check power consumption by using your multimeter in series with the power input set on the mA range – it should lie in the region of 30 to 50mA.

Check that there is +5V on the ICs.

Keyboard sensitivity setup

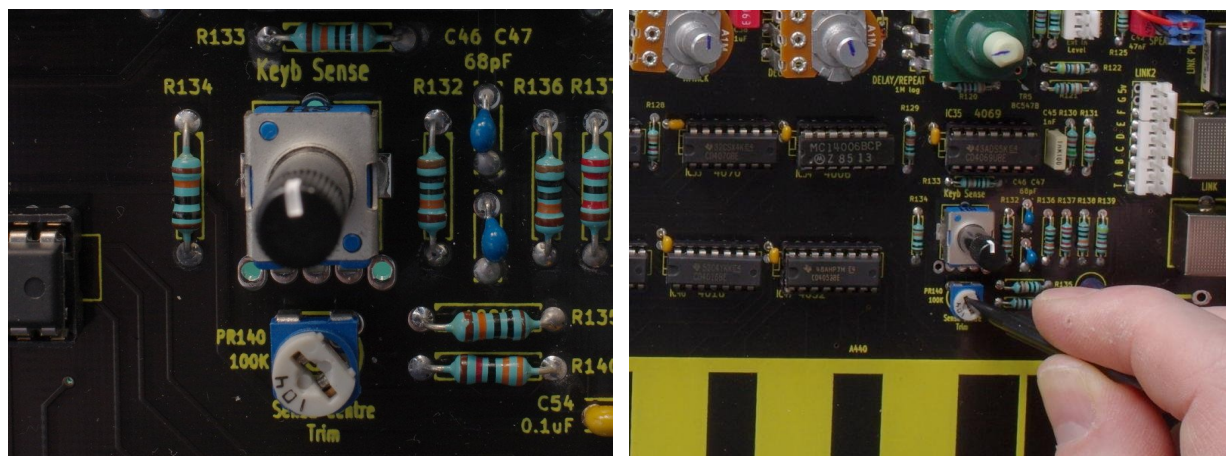

Turn the keyboard sense potentiometer to just past its central position, and PR140 6mm trimmer to its central position as well.

Turn PR140 until the synth self-triggers. Back off until the self-triggering stops. Now adjusting the keyboard sense trigger clockwise will increase the sensitivity until the keyboard self-triggers – and anti-clockwise will reduce the sensitivity so a heavier keypress will be needed to make the synth trigger, or even not trigger at all.

IC5 pin 8 has the keyboard scanning clock. This should have a period of about $35\mu\text{s}$. T keyboard trigger output – pad T on the LINK1 connector – is around 52Hz.

VCA Envelope trimmer

This trimmer adjusts the DC offset of the audio entering the filter. It should be adjusted so there is minimal click when the VCA is switched on.

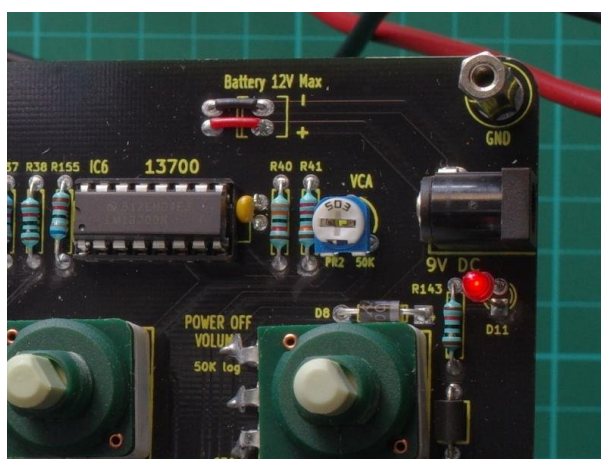

Switch each oscillator or the Off position. Turn the volume control fully on.

Turn the VCA Attack and Decay controls to fully off.

It is a good idea to connect some amplified speakers into the Line output. Turn up the volume so you can hear the background noise generated by Jasper. It will sound horrible. Make sure the oscillators and noise are switched off.

Press a key on the keyboard to trigger the envelope. You will hear additional noise and bleed-

through from the oscillators. There will be a click or thump when you press your finger on the keyboard.

Adjust the VCA trimmer until this click is minimised.

Reduce the volume on your speakers/amplifier and try the VCA.

LFO Trimmer

The LFO trimmer is used to adjust the symmetry of the control oscillator waveform. Set it to its central position.

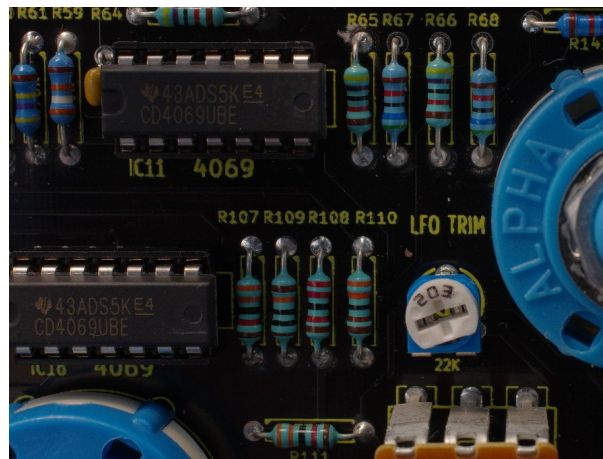

Only adjust it if you notice any major difference between the on-off of the square wave, or rise and fall of the 'sine'/ triangle waveform.

With an oscilloscope it is possible to accurately measure the mark-space or rise/fall ratio, and adjust the trimmer accurately.

VCO Separation Trimmer

This is used to adjust the oscillators so they stay in tune when the bend control is used.



Switch the oscillators to 8FT, pulse waveform.

Hold a key down and use the Oscillator 2 tune control so the two oscillators are tuned very closely and beat together slowly giving a sort of PWM effect. A slow beating of about 3Hz is good.

Turn the Bend control fully clockwise. If the oscillators start to beat more quickly or more slowly,

then adjust the trimmer to get the slow beating again.

Return the Bend control to its centre position, and adjust the frequency to get the slow beating again.

Turn the bend fully anti-clockwise – again adjust the trimmer if the frequencies start to vary again.

Repeat until there is none or very little variation in beating when the Bend control is used.

Tuning to A440

It is possible to tune Jasper to A – 440Hz. Switch Oscillator 1 on, to 8FT. Press and hold the upper A on the keyboard – it is marked A440 on the silkscreen above the keyboard. You can use the tuning pot to adjust the tuning to exactly 440Hz – or at least to within 1 or two Hz. You can check with the audio output connected to an oscilloscope, or using a frequency counter mode on a multimeter.

Further checking and troubleshooting

The Wasp Service Manual is largely valid for the basics of the tuning and troubleshooting on the Jasper circuit. If you want to know more about the working of the circuits, it is a very good place to start.

Images of its pages are available with a copy of the original schematic on the Synth DIY website: <http://www.synthdiy.com/show/?id=648> and other places on the net.



Options

Link Wiring

The link port is a tri-state bus and uses 5V TTL logic levels.

- T Trigger (approx 50Hz pulse when active)
- A-D Note in octave (0-11)
- E,F Octave (0-2)

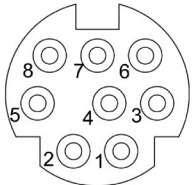
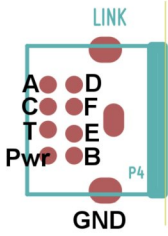
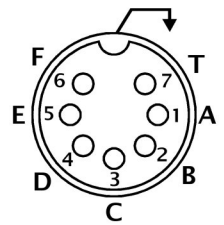
Mini DIN	Mini DIN 8 socket	Mini DIN 8 PCB	7 pin DIN wiring
1. F Most sig bit	 <p>Front view of socket Shield = GND</p>	 <p>top view</p>	 <p>Front view of plug or rear view of panel socket</p>
2. E			
3. D			
4. C			
5. B			
6. A Least sig bit			
7. T			
8. Pwr			

* Ignore the pin numbers – if you're making cables, just make sure the letters match up.

Full size 7pin DIN connection

If you wish to use a full size DIN socket to connect to vintage EDP gear, you can either make a cable with mini-DIN on one end and a full size DIN plug on the other.

Alternatively add a large 7pin DIN socket for the Link port inside your case – use the LINK2 header next to the mini-DIN sockets on the right-hand side. Alternatively if the mini-DIN sockets are not used, then leave out the 7 way ribbon cable underneath the PCB and solder the wires or header to the centre of the board, as was done with the original Wasp synth.

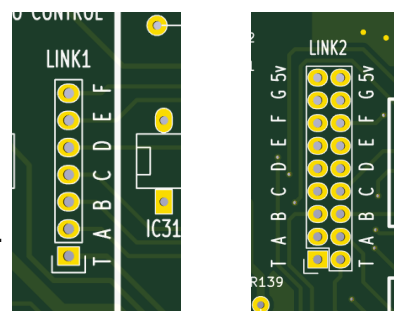

Internal MIDI-Link converter

An internal MIDI-Link converter can be connected to one side of the LINK2 footprint. 5V and GND are made available for such a converter. A microcontroller like Arduino or Teensy can be used if you want to DIY.

Elby Designs produce the [miniMIDI-Wasp](#) MIDI adapter which works with Jasper. Use the 5V and GND pins of the LINK2 header to power it, and connect the remaining pins of LINK2 to the LINK header on the miniMIDI-Wasp PCB. In the order ABCDEFT.

Quarter inch jack sockets

The Jasper PCB has pads for Cliff FCR-1295 stereo 3.5mm jack sockets. Although they are wired as stereo, only a mono signal is produced by the synthesizer, so it is only necessary to wire the tip and shield conductors. Switched jacks should be used, as plugging in a jack in disconnects the speaker from the circuit.

For the audio input circuit, the input signal is switched to GND until a jack is plugged in. Solder wires from the pads to the relevant pins on your 1/4" sockets. The pad spacing is 3.8mm – so it may be possible to use headers. A good 1/4" alternative to the 3.5mm version is the Cliff CL1220A – but other suitable switched sockets would be suitable.

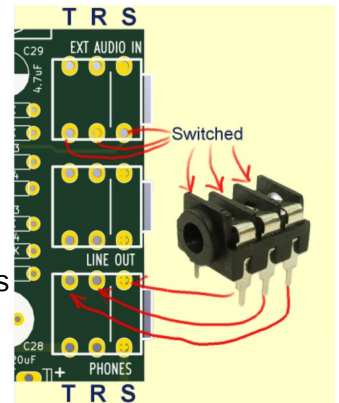

Power Options

If you don't want to use the on-board DC jack, you have a couple of options:

- solder a panel mounted jack via flying wires to the DC jack pads on the PCB. This allows use of a battery pack in addition to the external DC
- use a panel mounted jack and a 2 pin Molex or MTA-100 plug that fits to the power header at the top of the PCB. In this case either solder in a DC jack onto the PCB or jumper the pads shown right in green.

The power input part of the schematic is shown below. When DC jack is plugged in, the battery's negative terminal is disconnected.

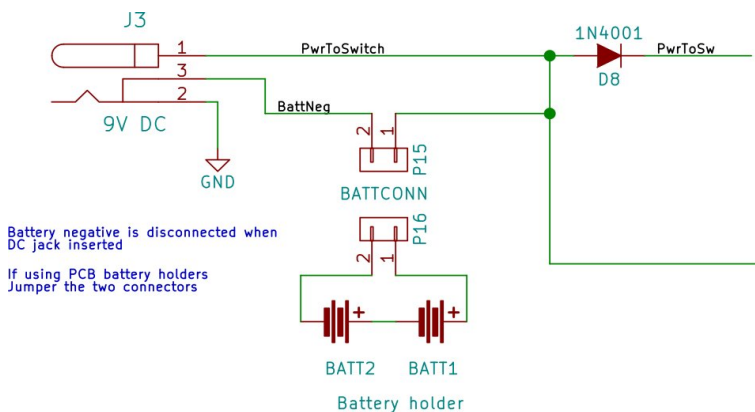
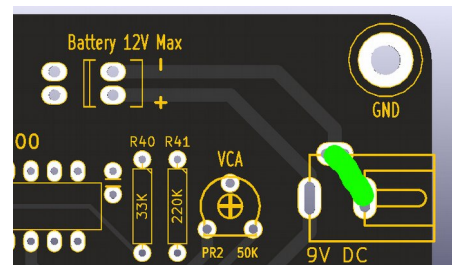

Further Information

For full test and setup details, and pretty comprehensive description on the functioning of the circuits, check the Wasp Test Instructions/Service Manual. Images of its pages are available with a copy of the original schematic on the Synth DIY website: <http://www.synthdiy.com/show/?id=648> and other places on the net.

Crazy Patroche [did a full rebuild of his Wasp.\(translated\)](#). Very smart with clear renderings of the PCB traces that helped me lay out the initial version of the Jasper PCB, and work out differences between the Wasp PCB and original schematic.

<http://www.crazy-patroche.com/article-les-aventures-d-un-wasp-102961878.html>

Tim Stinchcombe has scanned a copy of the original Wasp User Manual on his [EDP Gnat pages](#): http://www.timstinchcombe.co.uk/synth/gnat/wasp_user_manual_bw300dpi.pdf

Elby Designs produce the [miniMIDI-Wasp MIDI-LINK adapter](#) as a kit and assembled. They also produce [the Pixie](#), an updated and expanded Wasp clone. In the Pixie documentation is an excellent redrawn schematic of the Wasp, that I used to clarify some points where the original schematic was unclear.

<http://www.elby-designs.com/contents/en-us/p56.html>

<http://www.elby-designs.com/contents/en-us/d11.html>

Latest information about Jasper can be found in these Muffwiggler DIY forum threads:

Jasper general thread: <https://www.muffwiggler.com/forum/viewtopic.php?t=151625>

Jasper build thread: <https://www.muffwiggler.com/forum/viewtopic.php?t=157937>

More about the Wasp

The [Wikipedia article](#) gives a good overview of EDP, its products and legacy.

https://en.wikipedia.org/wiki/Electronic_Dream_Plant

Chris Carter of Throbbing Gristle wrote a fairly comprehensive article [about the Wasp for Sound On Sound magazine](#) in 1995. The unedited version is on [Chris Carter's website](#).

http://www.soundonsound.com/sos/1995_articles/feb95/edpwasp.html

http://throbbing-gristle.com/CHRISCARTER/content/sos/edp_wasp.html

Mark Vail's book *Vintage Synthesizers*, (published 2000, ISBN 0879306033) has a good few pages on British synthesizers including EDP and the Wasp. [Amazon.co.uk](#) [Amazon.com](#)

<http://www.amazon.co.uk/dp/0879306033/>

<http://www.amazon.com/dp/0879306033/>

<http://www.polynomial.com/edp-wasp/index.html> A good page of links and sound samples of the Wasp.